

Absolute / Incremental Singleturn Encoder 18 Bit

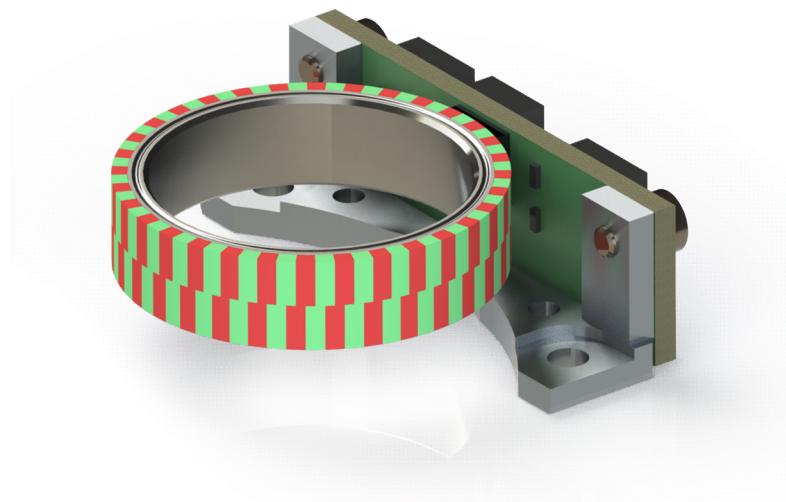

PWB encoders GmbH
Am Goldberg 2
D-99817 Eisenach
Germany
Phone: +49 3691 72580-0
Fax: +49 3691 72580-29

info@pwb-encoders.com
www.pwb-encoders.com

Description

The AS 25M/50M is a high-resolution, multi-functional encoder. It offers a variety of common encoder interfaces. The AS 25M/50M generates simultaneously position data as well as speed data. Thus, the encoder is ideal for positioning and rotation speed control.

The AS 25M/50M is based on radial Hall sensing of a two track magnetic wheel by using the nonius principle. The differential sensing offers the advantage of effectively suppressing homogenous magnetic interferences. This is the reason why static fields don't have a significant influence on output signals.

Features

- Singleturn encoder
- Magnetic sensing
- 2 port output (absolute + incremental simultaneously)
- Interface: SSI (synchron serial interface) (up to 18 Bit)
- BiSS ® (bidirectional serial synchron) (up to 18 Bit)
- SPI (serial peripheral interface) (up to 18 Bit)
- ABI (incremental interface) (up to 65.536 cpr)
- UVW (commutation signals) (up to 16 pole pairs)
- Sin/Cos (analog interface) (up to 64 periods)
- Compact size
- Bearing free
- Operating temperature: -20°C to +85°C
- Compliant EU-directive 2011/65/EU (RoHS)



SPI

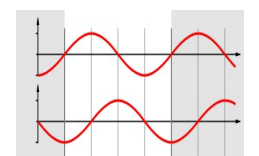
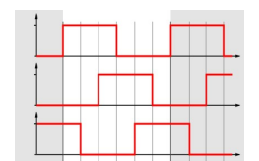
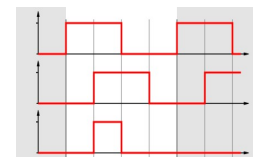

Applications

- Motor feedback
- BLDC motor commutation
- Hollow shaft
- Multi-axis measurement systems

Recommended operating conditions

Electrical characteristics are only effective for the range of the operating temperatures.
Typical values at 25 °C.

Parameter	Symbol	Min.	Typ.	Max.	Unit	Notes
Supply voltage	U_B	4.75	5.0	5.25	V_{DC}	
Supply current	I_{LB}	30	50	80	mA	no load
Reverse polarity protection	U_B	-36		0	V_{DC}	
Start up time	t_T		20		ms	
ESD voltage	U_{ESD}			2	kV	discharged over 1,5k Ω
SSI / BiSS / SPI						
Clock frequency	f	80		10000	kHz	
Scan ratio of T		40	50	60	%	
Time lag	t_V		150		ns	
Timeout (SSI)	t_m		20		μs	(BiSS = adaptive = T/2)
Rise time	t_r	3	11	25	ns	$R_L = 50\Omega, C_L = 100pF$
Fall time	t_f	3	11	25	ns	$R_L = 50\Omega, C_L = 100pF$
ABI / UWW						
High level output voltage	V_{oH}	2.0	3.0	5.25	V_{DC}	$R_L = 50\Omega$
Low level output voltage	V_{oL}			0.8	V_{DC}	$R_L = 50\Omega$
Output current per channel	I_{out}	-1.0		20	mA	overload protection
Sin/Cos						
Output driver current	I_A	-1		1	mA	
Analog amplitude	V_{SS}	0,9	1	1,2	V	with diff. evaluation
Analog offset	V_{Off}	2,3	2,5	2,6	V	
Environment						
Operating temperature	T_A	-20	25	85	°C	
Storage temperature	T_S	-40		85	°C	
System						
Relative Angular Accuracy			+/- 0,02		° m	depend on mechanic
Absolute Angular Accuracy			+/- 0,1		° m	depend on mechanic

ESD Warning: Normal handling precautions should be taken to avoid static discharge damage to the sensor.

Interface

Data transfer: SSI Gray-Code

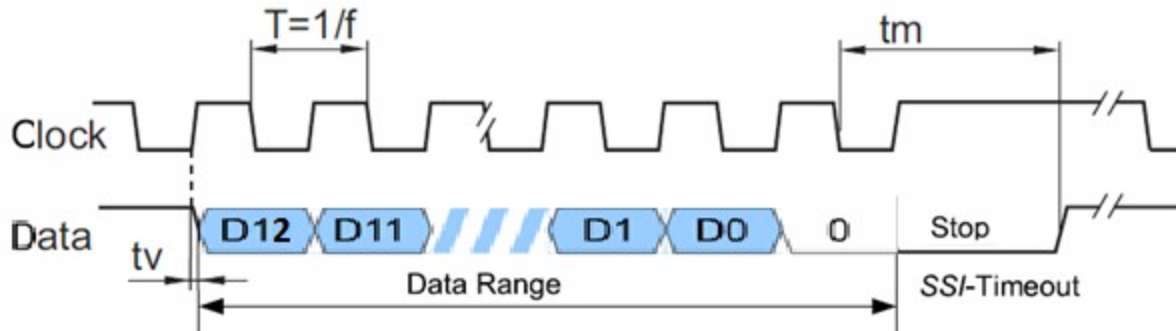

The position data increases, when the shaft rotates in the direction of clockwise.

Optionally the protocol is available with error bit. Further variations on request.

The resolution is eligible between 13Bit and 18Bit.

Data transfer: BiSS (C-Mode) Binary-Code

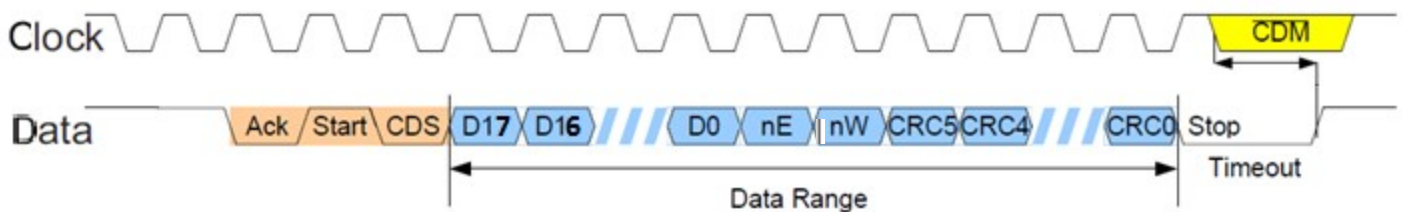

The position data increases, when the shaft rotates in the direction of clockwise.

Serial interface protocol	Definition
Ack	Acknowledge-Bit
Start	Start-Bit
CDS	Control-Bit
D0 - D17	Position-Data
nE	Low activ error
nW	Low activ warning
CRC0 - CRC5	Cyclic redundancy code
Stop	Stop-Bit
CDM	Control data master

For a detailed description of the protocol, see separate interface specification.

The standard resolution is 18Bit.

Interface

Data transfer: SPI

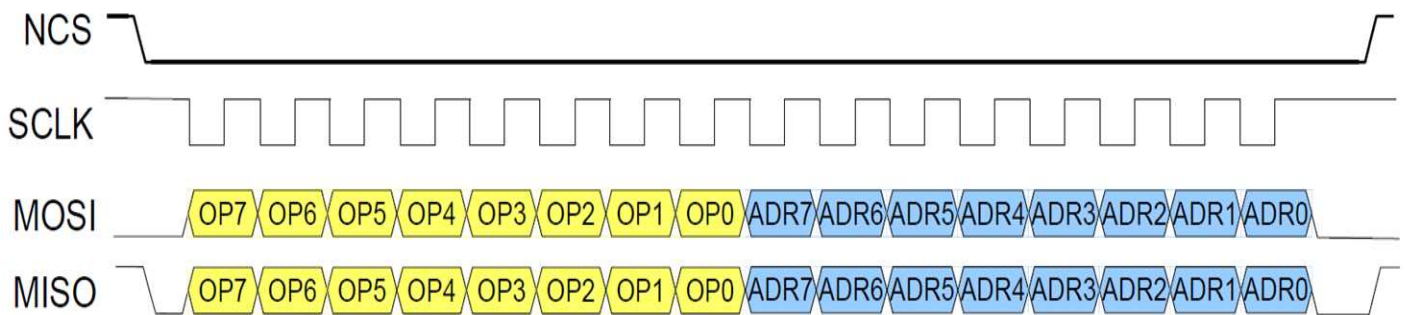

Figure: SPI transmission, using opcode READ REGISTER as an example

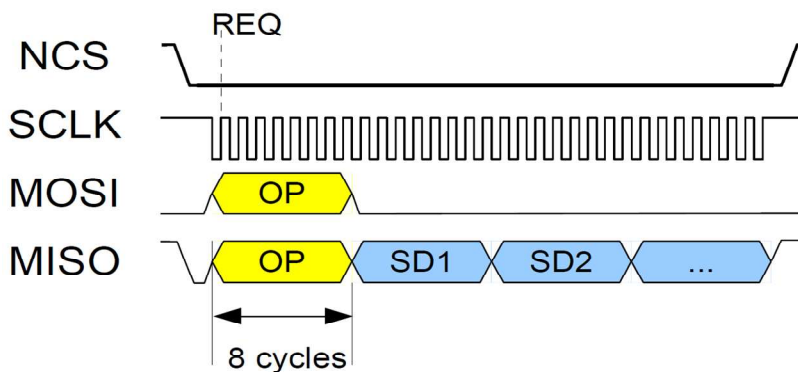

Figure: SPI transmission, READ SENSOR DATA

The Data is sent in packages of 8 bits and with the MSB first. Each data transmission starts with the master sending an opcode to the slave.
The standard resolution is 18Bit.

Optionally the protocol is available with low idle level on SCLK. Further variations are on request.

The direction of rotation can be inverted.

The zero position can be set free at every arbitrary position (Preset).

This interface is specially for the direct connection to the micro-controller from the customer.
It is appropriately for short cable length.

Interface

Incremental

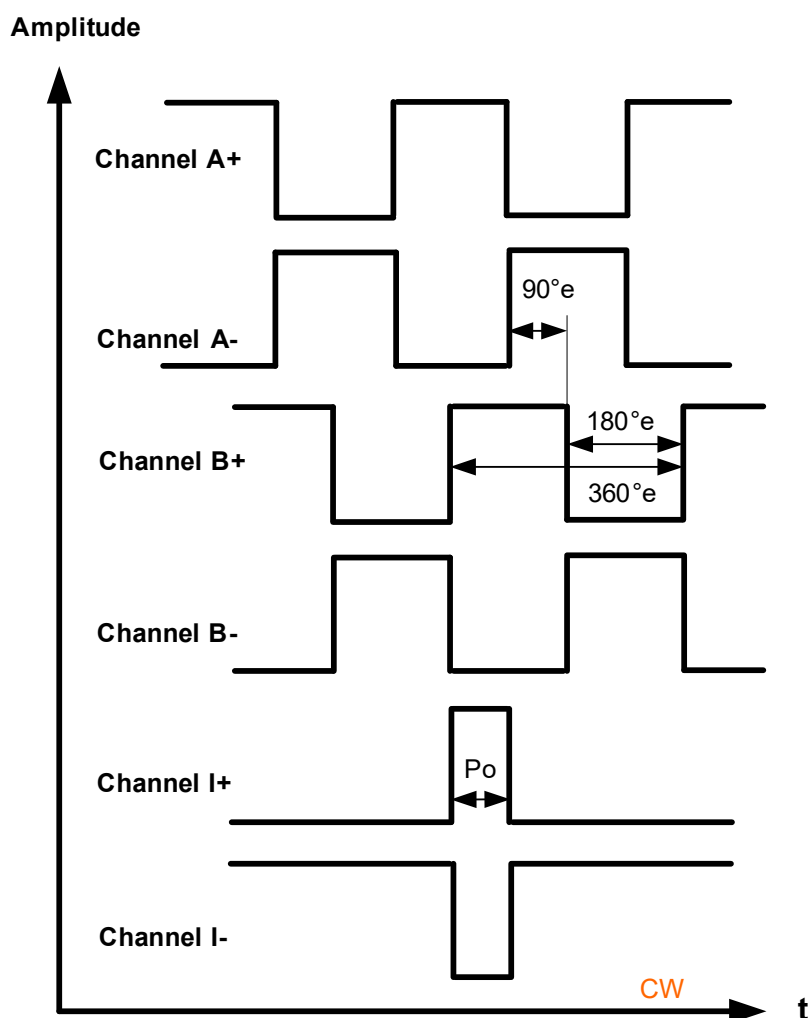

Figure: Incremental interface with differential signals

Optionally the Index pulse I (P_o) is available in four different lengths ($90^\circ e$, $180^\circ e$, $270^\circ e$ and $360^\circ e$).
 The position of the index pulse is in relation to the A/B signals.
 The direction of rotation can be inverted.
 The position of the Index can be set free (Preset).
 Further variations are on request.

The resolution of incremental signals ABI can be programmed for each singleturn cycle within a range of 4 to 262,144 edges. That means a resolution from 1 to 65.536 cpr.
 (1, 2, 3, 4, 5, ..., 65.535, 65.536)

Interface

Commutation

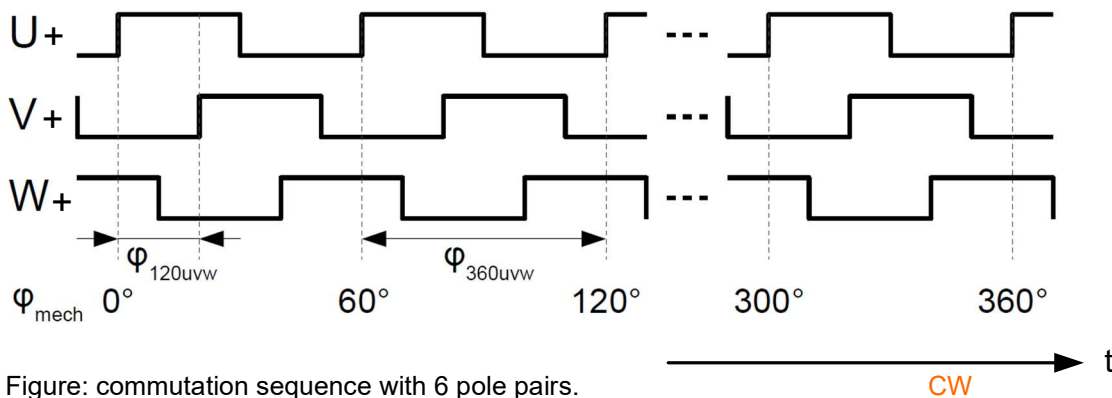

Figure: commutation sequence with 6 pole pairs.

The phaseshift between the commutation signals is 120° e.

The number of pole pairs for the commutation signals for BLDC motors are available from 1 up to 16. (1, 2, 3, ..., 14, 15, 16 pole pairs)

Optionally the direction of rotation can be inverted.

The start angle for the offset of the winding of the BLDC and the Hall sensor signals can be set free.

Interface

Analog

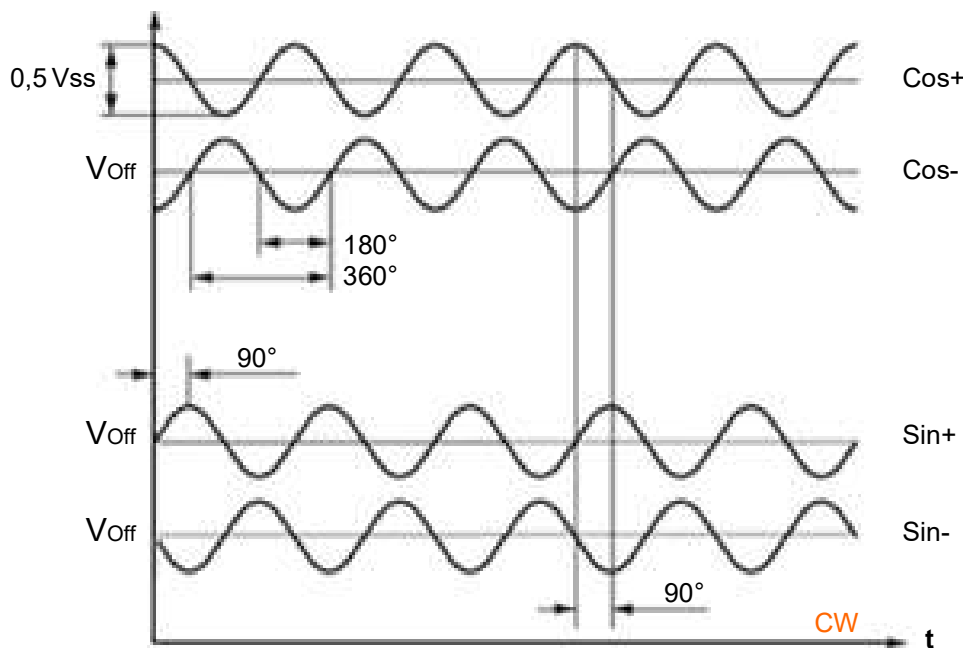

Figure: analog signals

The number of sinus / cosines signals per revolution are depended on the magnet outer diameter:

- AS 25M: 32 Sin/Cos
- AS 50M: 64 Sin/Cos

As result of the differential evaluation of the both complementary signals Sin+ and Sin- as well as Cos+ and Cos- by using the recommended receiving circuit (see page 9) you will get a Sinus and a Cosinus signal with an amplitude of $1V_{ss}$.

Typical operating circuit *

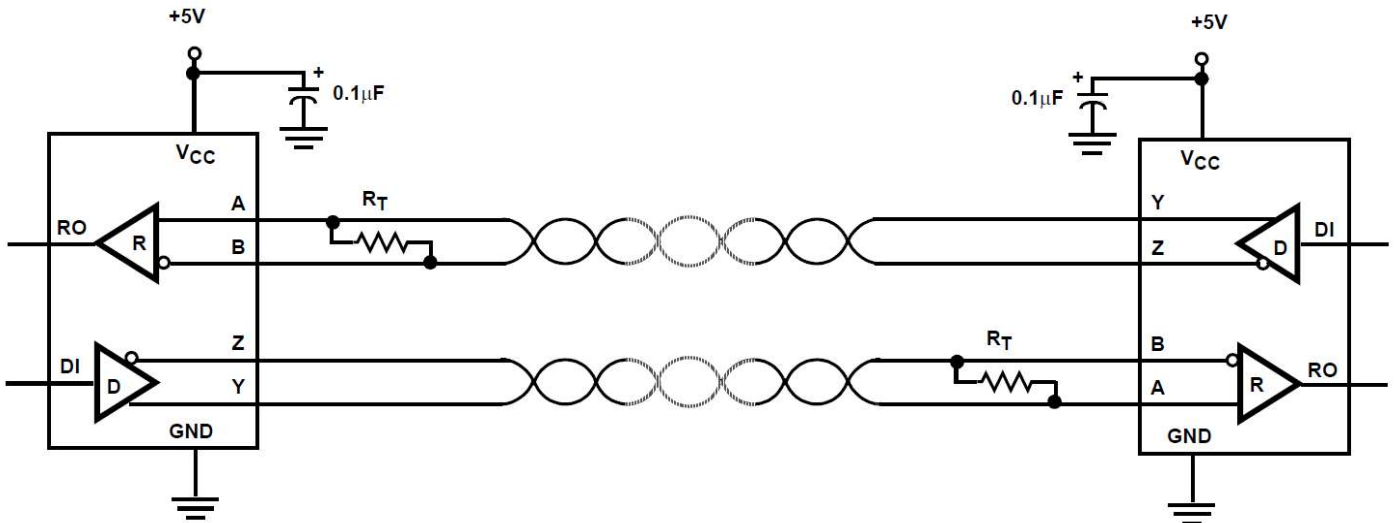

* for SSI, BiSS, ABI, UVW and Sin/Cos**

** for Sin/Cos: $R_T = \infty$

Rotation direction

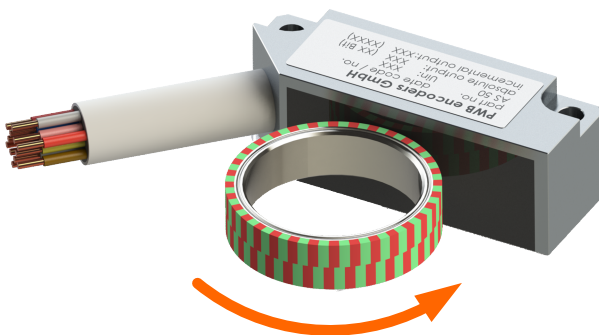

Rotation direction clockwise (count up)

PWB encoders GmbH RESTRICTED

THIS DOCUMENT AND ANY ASSOCIATED DATA CONTAINS RESTRICTED INFORMATION THAT IS PROPERTY OF PWB encoders GmbH AND MAY NOT BE DISCLOSED OR DUPLICATED FOR OTHERS EXCEPT AS AUTHORIZED BY PWB encoders GmbH

INFORMATION CONTAINED IN THIS PUBLICATION MAY BE SUPERSEDED BY UPDATES. IT IS YOUR RESPONSIBILITY TO ENSURE THAT YOUR APPLICATION MEETS WITH YOUR SPECIFICATIONS.

Mechanical Notes

Parameter	Value	Tolerance	Unit
Magnet wheel outer diameter \varnothing	24.5 / 50.7	± 0.1	mm
Shaft diameter \varnothing_w	10 / 14 / 20 / 39.5 / 44 *	± 0.01	mm
Permissible radial displacement	0	± 0.1	mm
Permissible tangential displacement	0	± 0.2	mm
Permissible axial displacement	0	± 0.3	mm
Permissible eccentricity	0	± 0.05	mm
Sensor to magnet wheel distance	0.20	± 0.05	mm
Moment of inertia of the magnet wheel	20.0	± 1.0	gmm^2
Mounting screw size	M2,5 x 6	-	-
Tightening torque of the screws	30	-5	Ncm
Permissible rotational speed AS 25 M	12.000	-	rpm
Permissible rotational speed AS 50 M	6000	-	rpm
Total weight	25	-	g
Protection grade according to DIN 40500	IP00	-	-

* Customer specific magnet wheels are accomplishable on request.

Mechanical Positioning

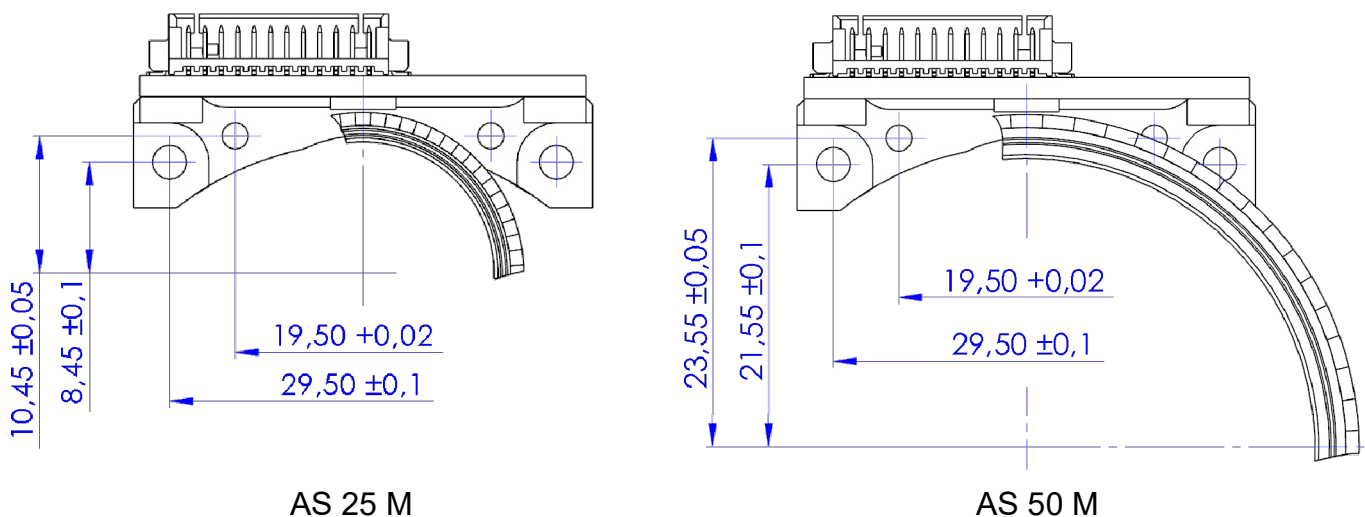

Mechanical Dimension

Encoder Head

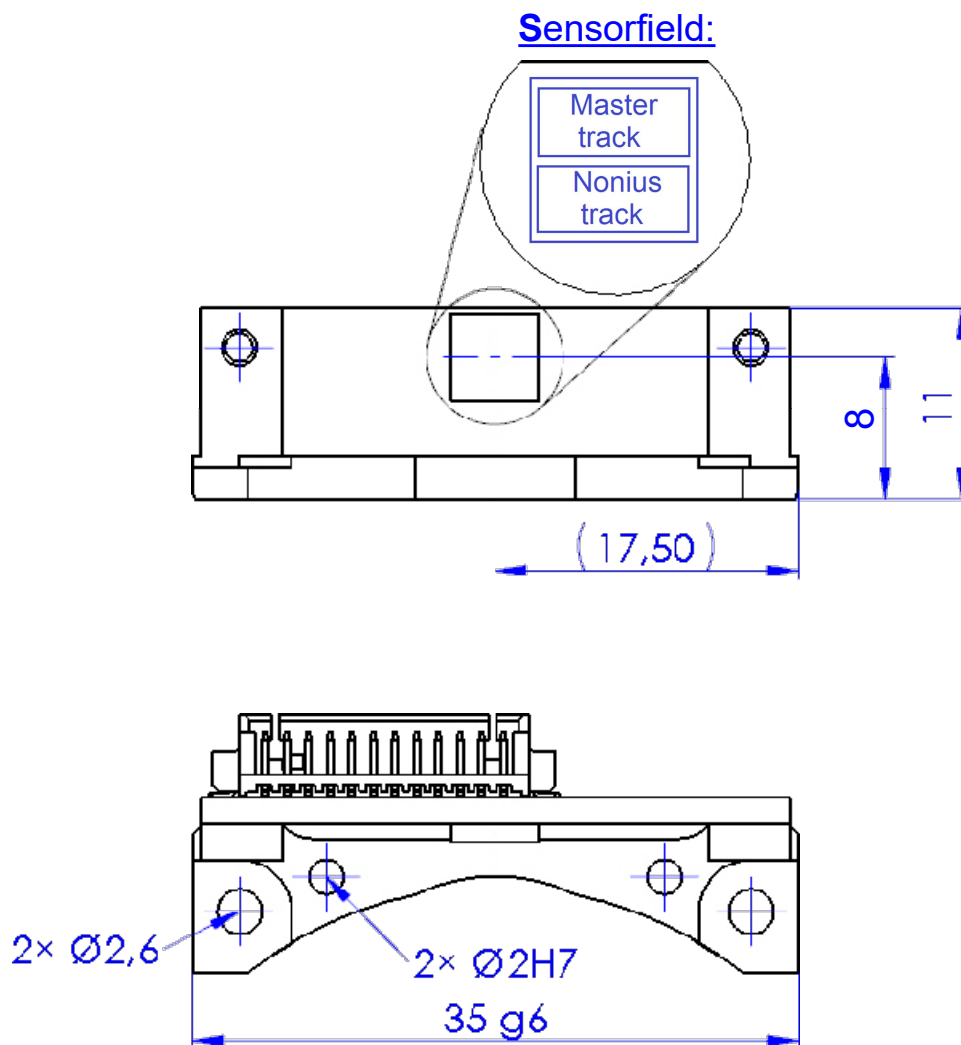

The Encoder head and the accompanying magnet wheel constitute an unit which belongs together. Every Encoder Head is initialised for his own accompanying magnet wheel. He is matched with the magnet wheel and programmed by his first operation by PWB encoders GmbH.

Don't mix up this combination with other ones.

If you exchange the magnet wheel, it may be in function, but the values at the datasheet couldn't guarantee.

Exchange between different magnet wheel sizes are not possible.

Magnet wheel options for AS25M

**Screwed Version:
103603**

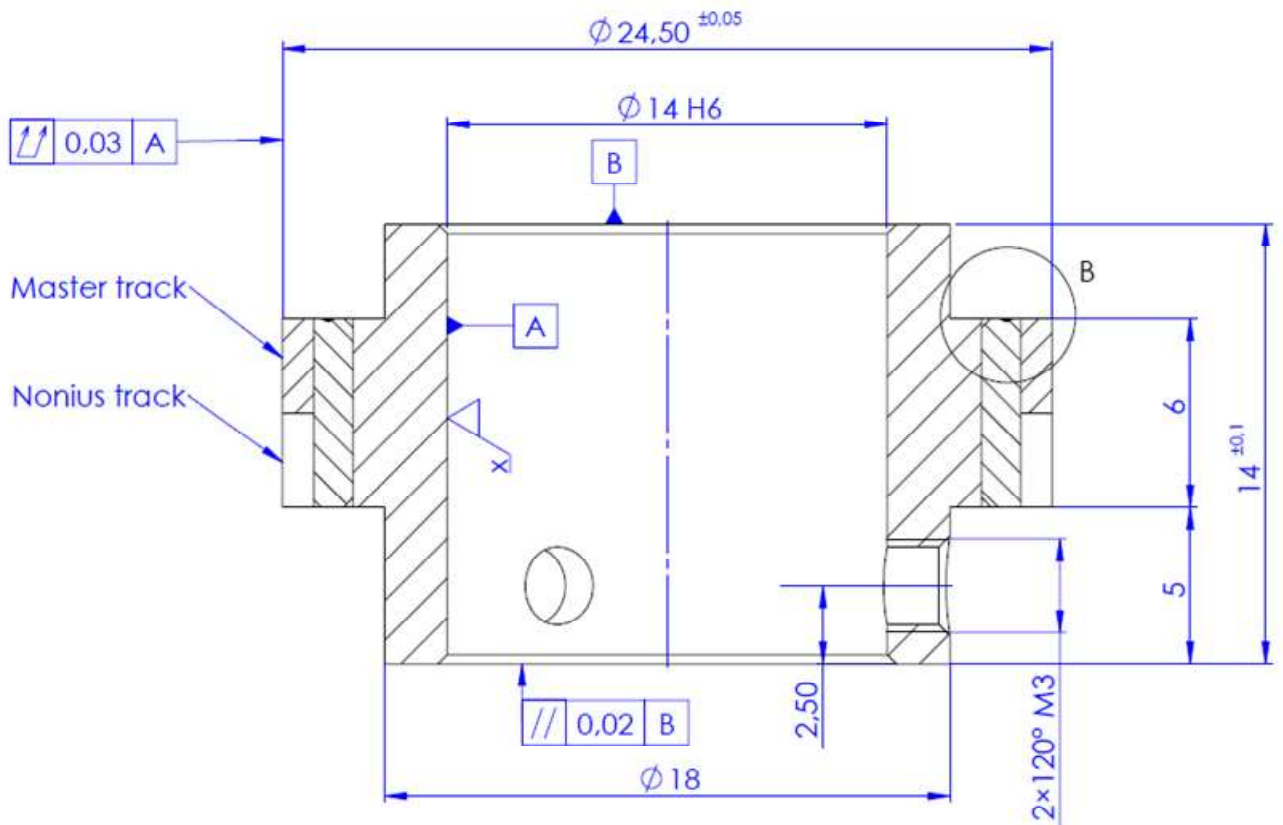

unbemaßte Fasen 0.3×45°

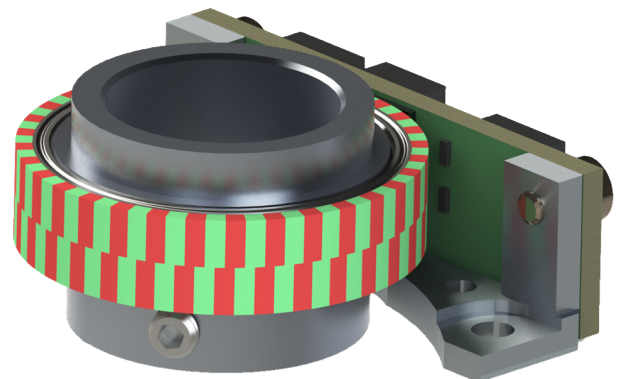
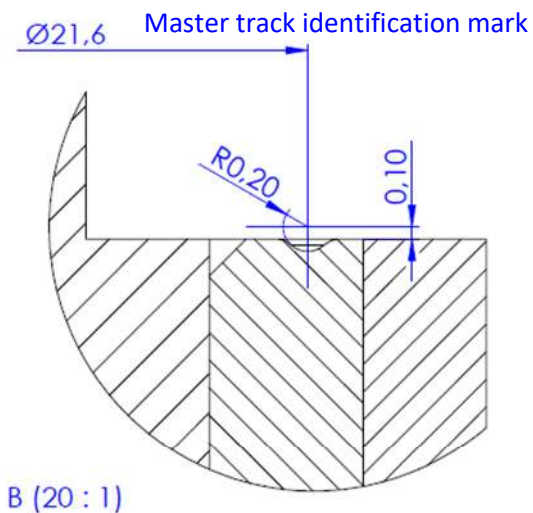

Magnet wheel options for AS25M

Press fit version:
102417

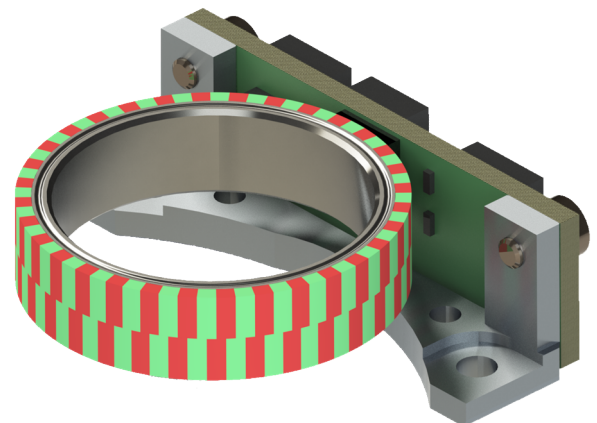
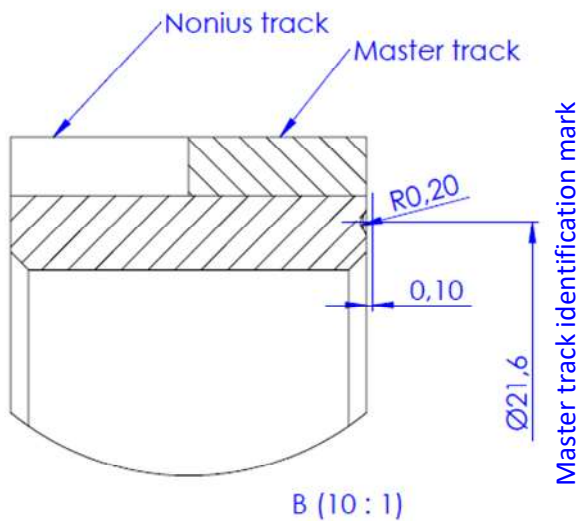
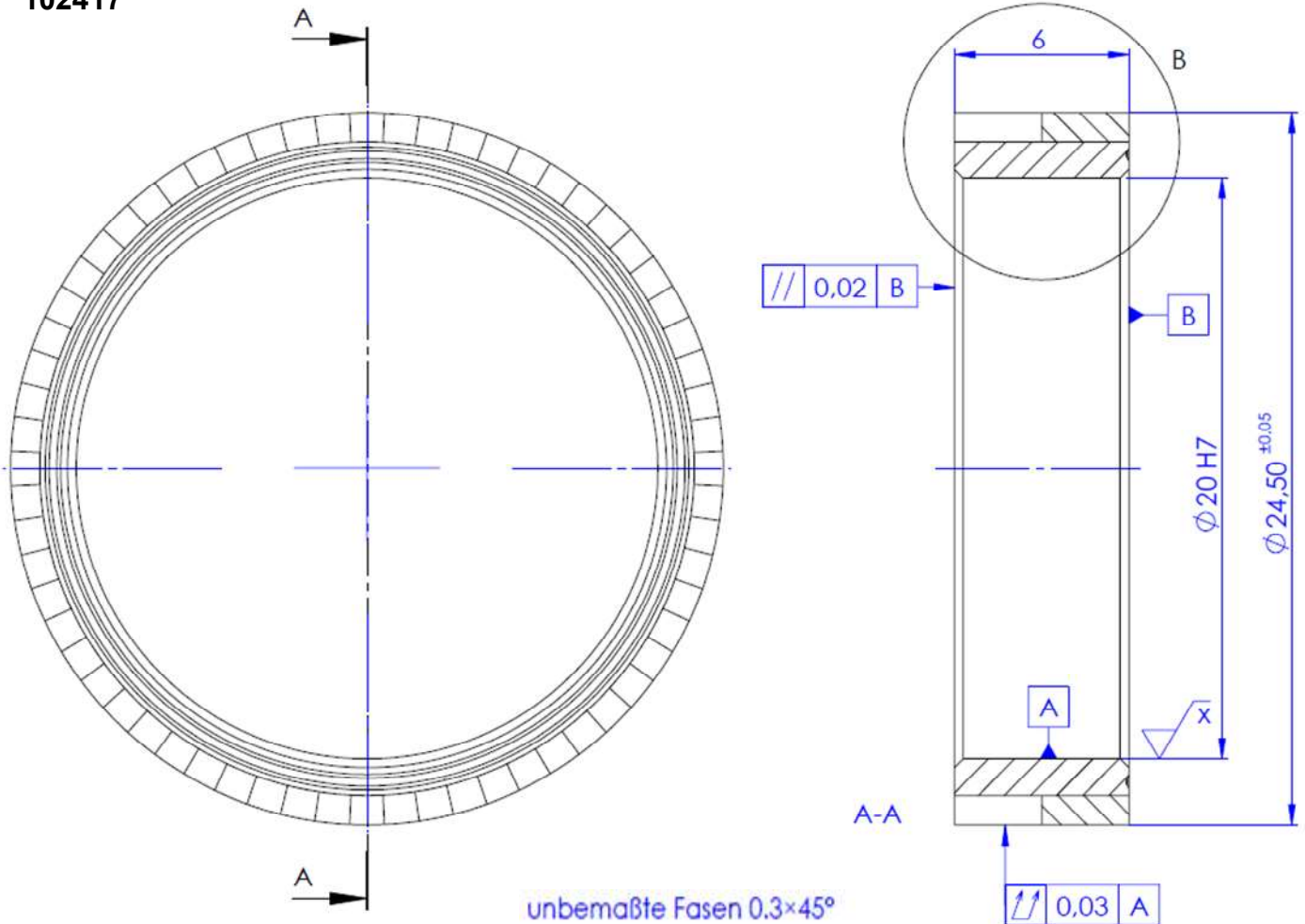

Magnet wheel options AS50M

Screwed Version:
103606

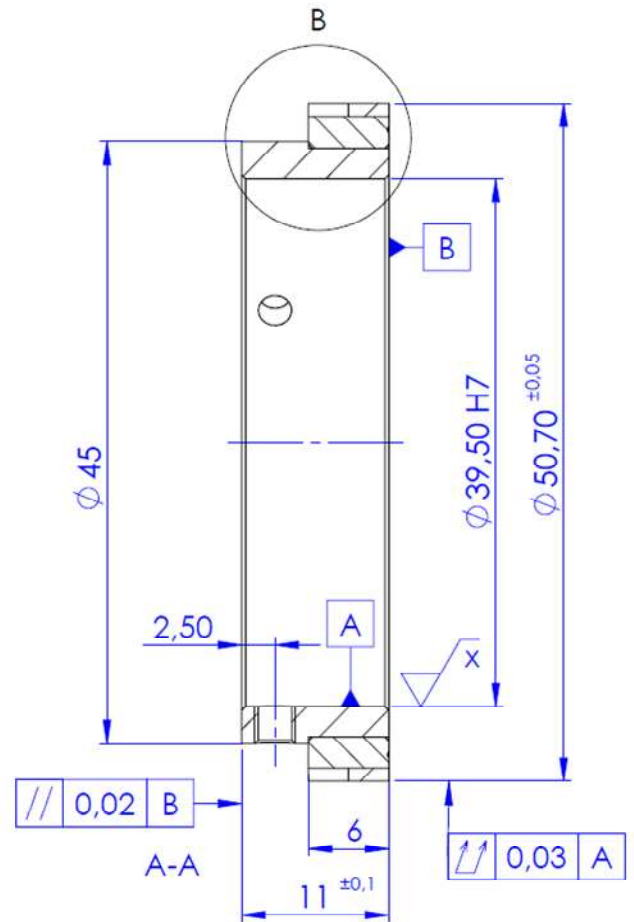
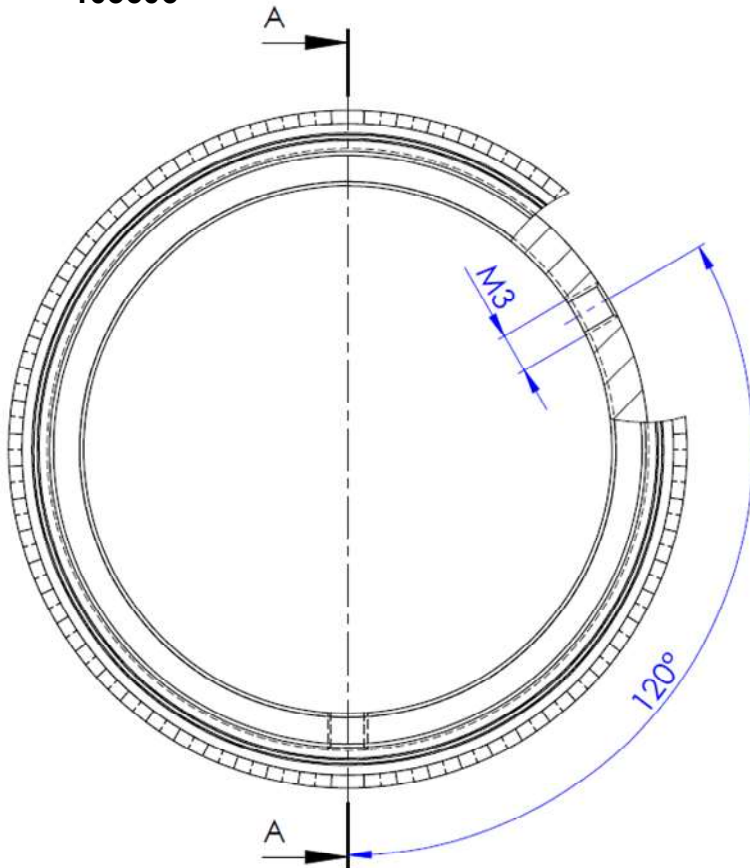

unbemaßte Fasen $0,3 \times 45^\circ$ Nonius track Master track

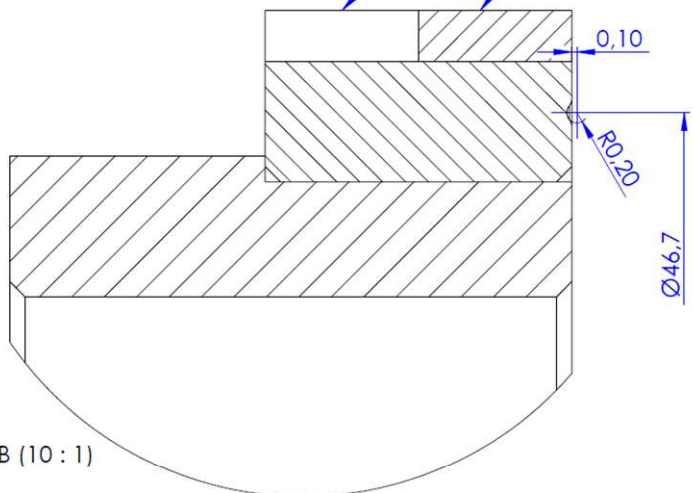

Master track identification mark

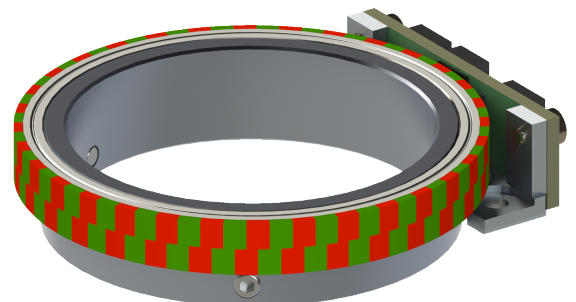

Magnet wheel options AS50M

Press fit version:
103198

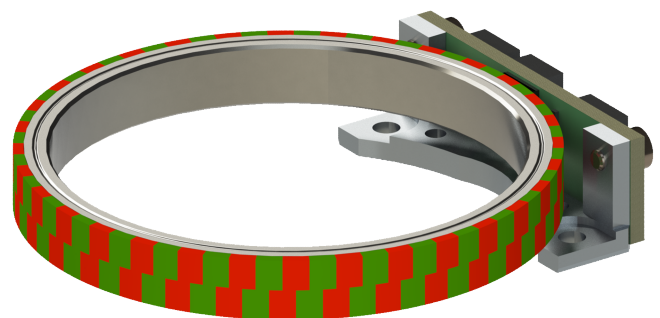
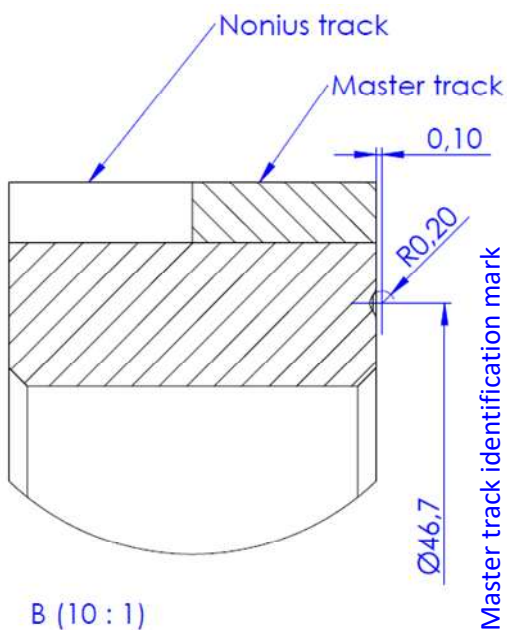
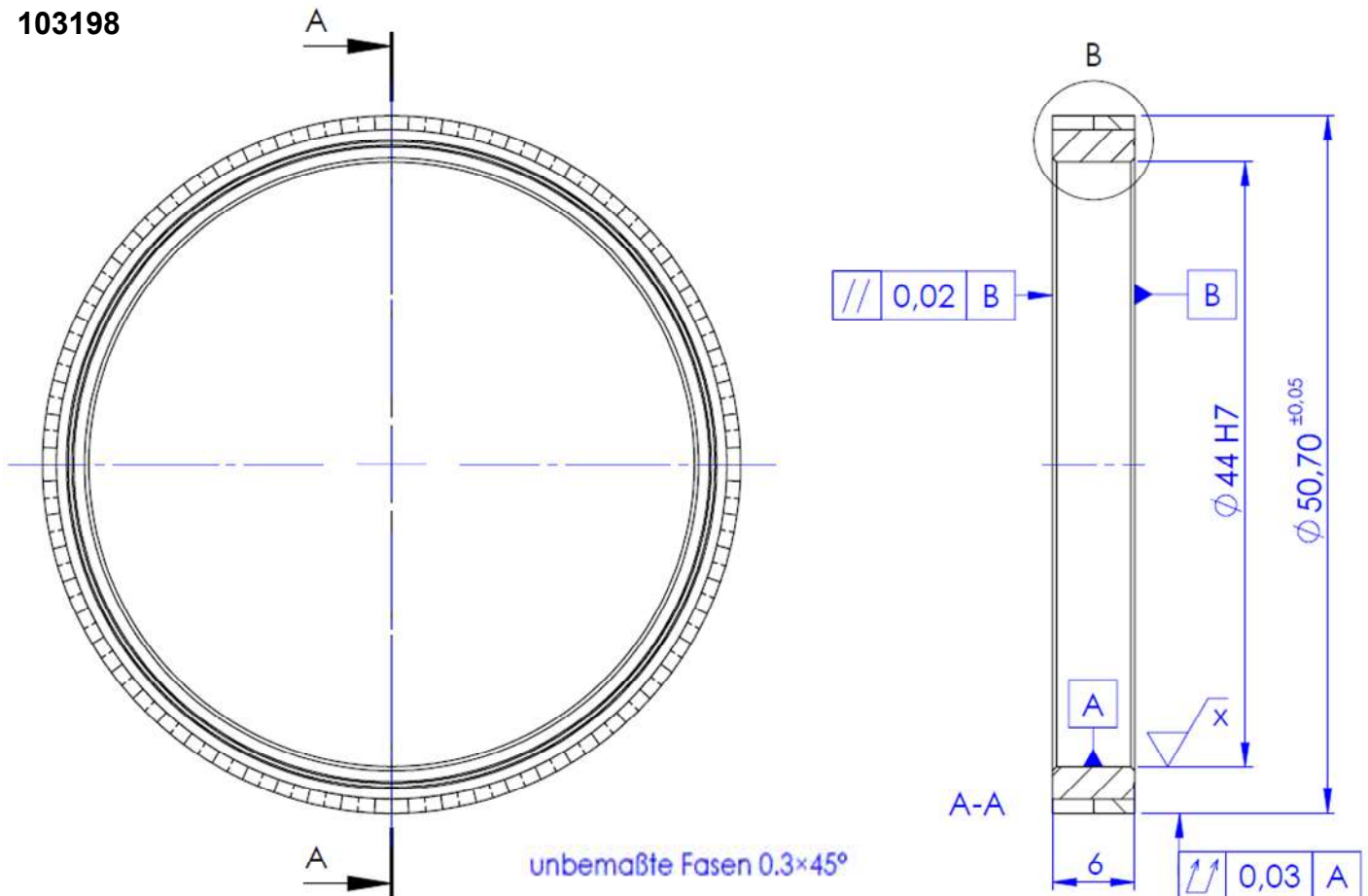

Terminal assignment

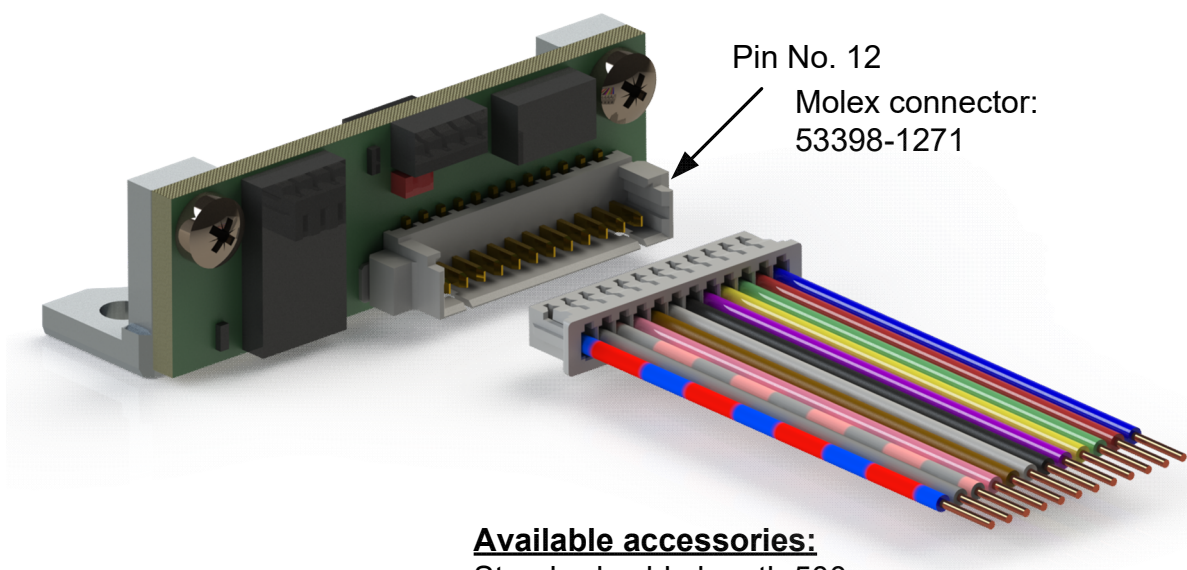

Available accessories:
Standard cable length 500 mm
(AWG 28)

Pin-out description

<i>signal description</i>					<i>connector</i>		<i>cable</i>
SPI	SSI, BiSS	ABI	UVW	Sin/Cos	Supply	Pin No.	color of wire
					GND	12	blue
					UB	11	red
		A+	U+	Sin+		10	green
		A-	U-			9	yellow
		I-	W-	Cos-		8	purple
		I+	W+	Cos+		7	black
		B-	V-			6	white
		B+	V+	Sin- *		5	brown
MISO	Da+					4	pink
MOSI	Cl-					3	pink/grey
NCS	Da-					2	grey
SCLK	Cl+					1	blue/red

* for shielded and twisted-pair cable Sin- is yellow

Ordering information

Ordering code:

AS25M - 10 - SSI 18 - ABI 1024 - 5 - 0,0 - S

Mag. Wheel Diameter	Shaft Diameter	Interface Absolute	Resolution Absolute	Interface Incremental	Resolution Incremental	Supply Voltage	Cable Length	Encoder Option
16: -	-	SSI ->	13: 13 Bit 18: 18 Bit	ABI ->	1 cpr cpr 1024 cpr cpr 65536 cpr	05: 5V	0.0 m 0.5 m	S: Standard E: Extended
25: 24.5mm ->	10 mm 14 mm 20 mm	BiSS ->	18: 18 Bit	UWV ->	1 pp ... pp 16 pp			
50: 50.7mm ->	39,5 mm 44 mm	SPI ->	18: 18 Bit	SIN ->	32 sin (AS25M) 64 sin (AS50M)			

The incremental interface and the absolute interface are chosen freely in combination.

The encoder must be calibrated during initial commissioning.

IMPORTANT NOTICE

The guarantee will be voided by misuse, accident, modification, unsuitable physical or operating environment, operation in other than the specified operating environment, or failure caused by a product for which **PWB encoders GmbH** is not responsible.

PWB encoders GmbH reserves the right to make corrections, modifications, enhancements, improvements, and other changes to its products and services also datasheets at any time.

Available accessories

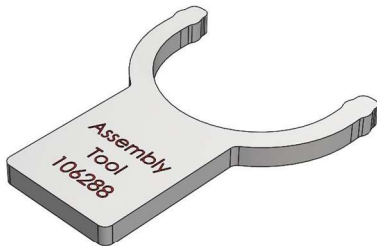

Art. Nr.: 106288: Assembly Tool for AS25
Thickness 5mm
For the magnet wheels as press fit version
with max. shaft diameter 20mm

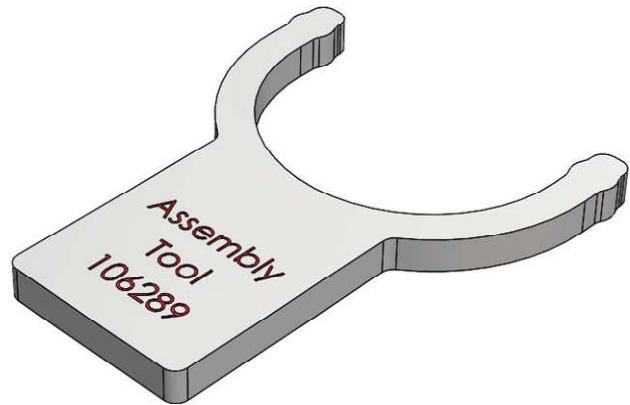

Art. Nr. 106289: Assembly Tool for AS50
Thickness 5mm
For the magnet wheels as press fit version
with max. shaft diameter 44mm

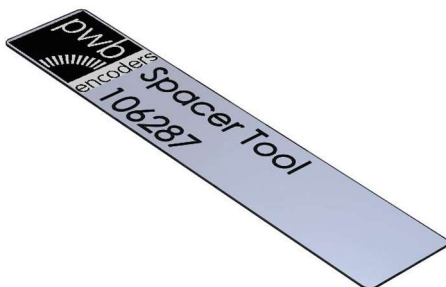

Spacer Tool for AS25 and AS50
Thickness 0,2mm

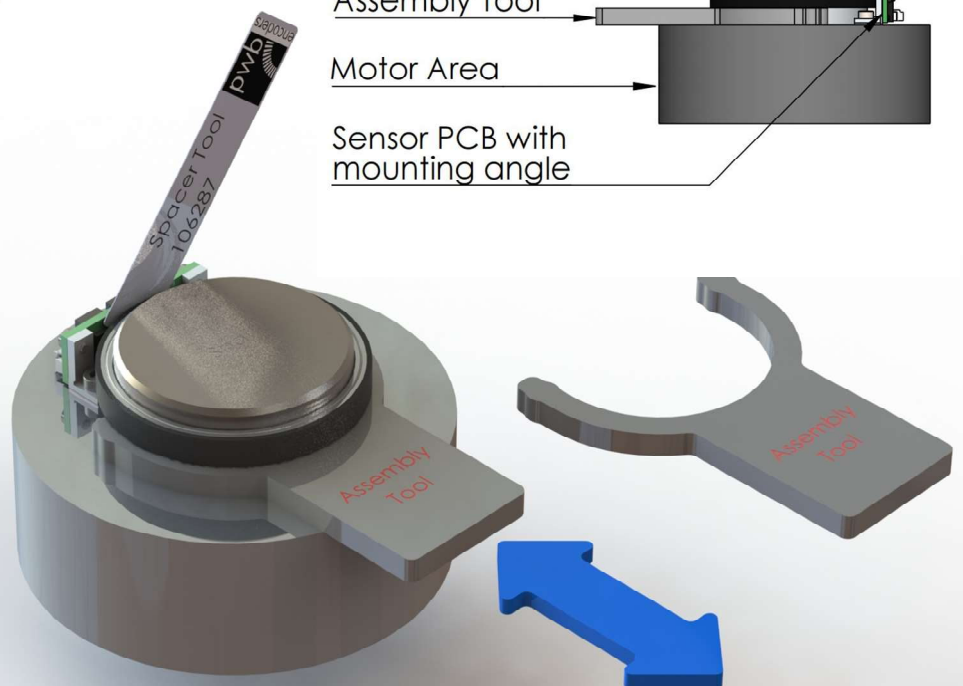
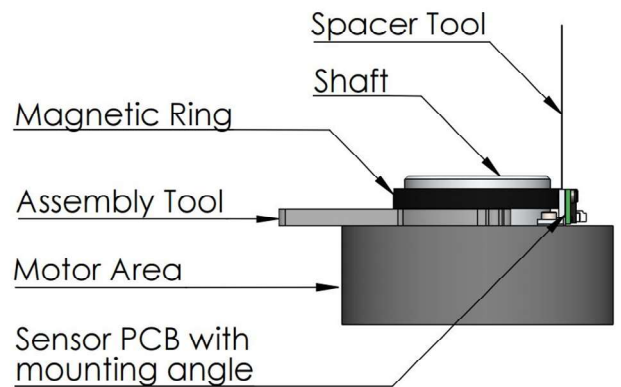

MOUNTING INSTRUCTION AS25M

1

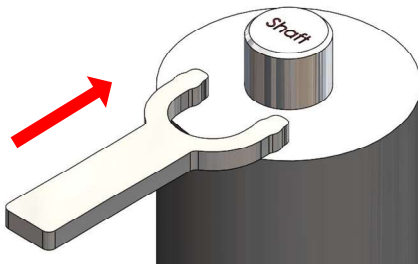

Set the Assembly Tool onto the motor

2

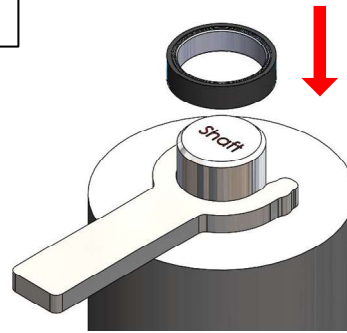

Put the magnet wheel onto the motor shaft

3

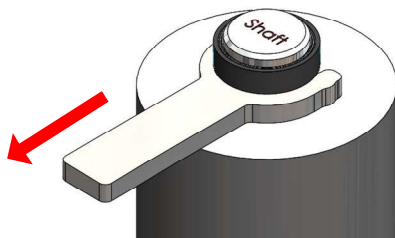

The magnet wheel and the Assembly Tool must lie flat
Remove the Spacer Tool

4

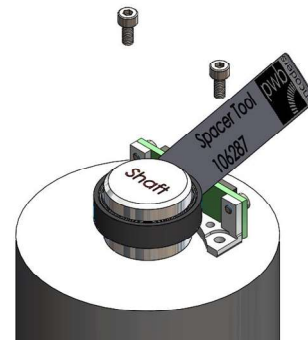

Set the Spacer Tool between the magnet wheel and the sensor head

5

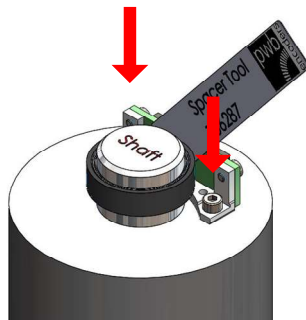

Tighten the screws

6

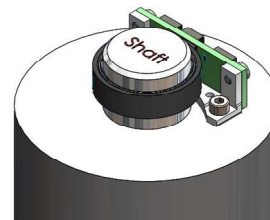

Remove the Assembly Tool

MOUNTING INSTRUCTION AS50M

1

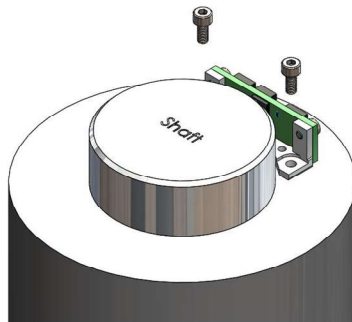

Set the "Encoder head" onto the motor

2

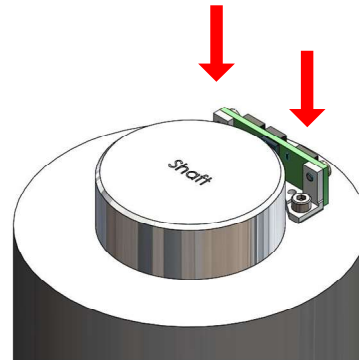

Tighten the screws

3

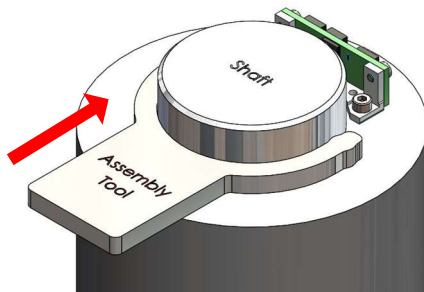

Set the Assembly Tool onto the motor

4

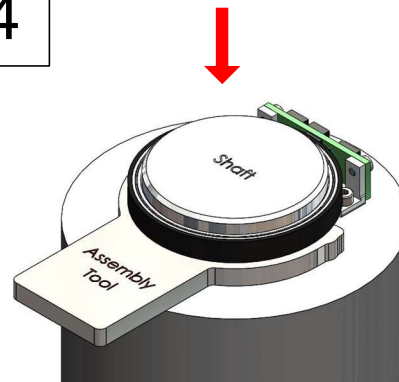

Put the magnet wheel onto the motor shaft

5

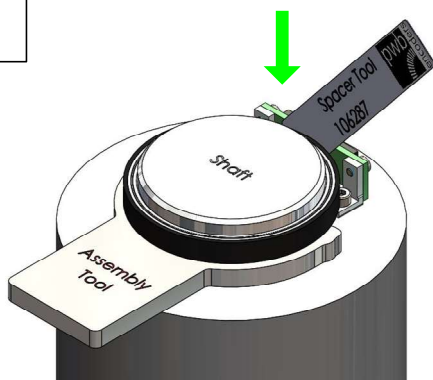

Check the distance between the magnet wheel and the sensor head using the Spacer Tool

6



Remove the Spacer Tool and the Assembly Tool

Magnet wheel für AS25

Customer specific – wheel
Screwed Version
101798

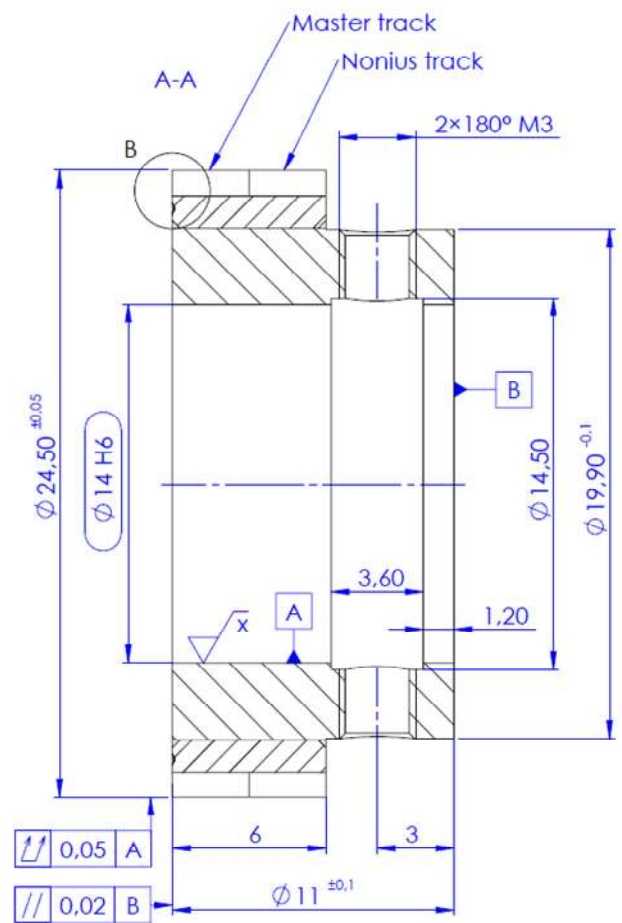
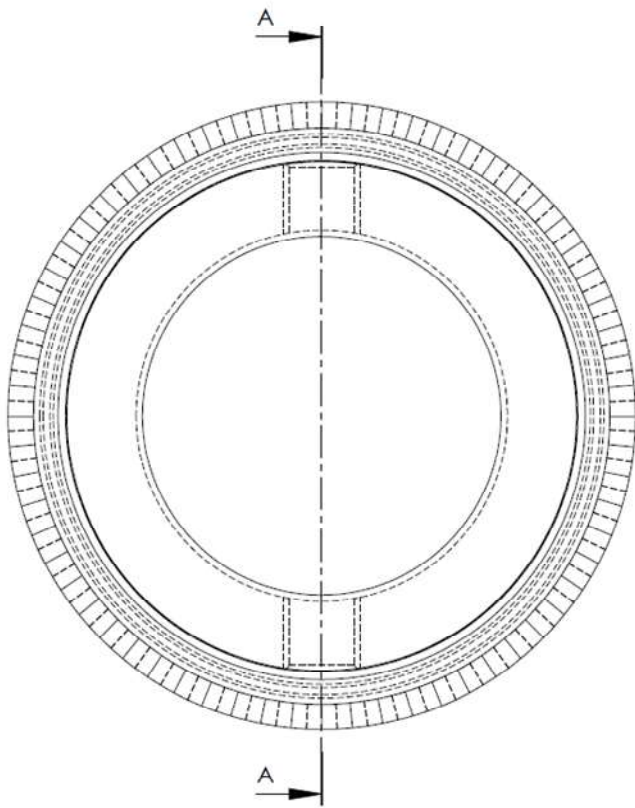

Master track identification mark

