



## Description

The AS 25/50 is a high-resolution, multi-functional encoder. It offers a variety of common encoder interfaces. The AS 25/50 generates simultaneously position data as well as speed data. Thus, the encoder is ideal for positioning and rotation speed control.

The AS 25/50 is based on radial Hall sensing of a two track magnetic wheel by using the nonius principle. The differential sensing offers the advantage of effectively suppressing homogenous magnetic interferences. This is the reason why static fields don't have a significant influence on output signals.

## Features

- Singleturn encoder
- Magnetic sensing
- 2 port output (absolute + incremental simultaneously)
- Interface: SSI (synchron serial interface) (up to 18 Bit)
- BiSS ® (bidirectional serial synchron) (up to 18 Bit)
- SPI (serial peripheral interface) (up to 18 Bit)
- ABI (incremental interface) (up to 65.536 cpr)
- UVW (commutation signals) (up to 16 pole pairs)
- Sin/Cos (analog interface) (up to 64 periods)
- High protection class
- Compact size
- Bearing free
- High shock and vibration resistant
- Operating temperature: -20°C to +85°C
- Compliant EU-directive 2011/65/EU (RoHS)



# SPI

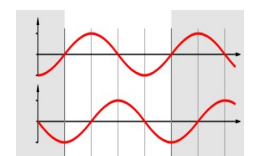
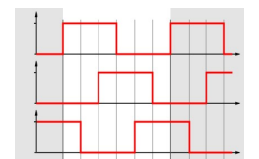
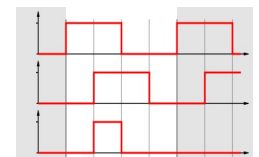

## Applications

- Motor feedback
- BLDC motor commutation
- Hollow shaft
- Multi-axis measurement systems

## Recommended operating conditions

Electrical characteristics are only effective for the range of the operating temperatures.  
Typical values at 25 °C.

Parameter	Symbol	Min.	Typ.	Max.	Unit	Notes
Supply voltage	$U_B$	4.75	5.0	5.25	$V_{DC}$	5V version
	$U_B$	7.75	12	30	$V_{DC}$	8-30V version
Supply current	$I_{UB}$	30	50	80	mA	no load
Reverse polarity protection	$U_B$	-36		0	$V_{DC}$	
Start up time	$t_T$		20		ms	
ESD voltage	$U_{ESD}$			2	kV	discharged over 1,5k $\Omega$
<b>SSI / BiSS / SPI</b>						
Clock frequency	f	80		5000	kHz	
Scan ratio of T		40	50	60	%	
Time lag	$t_v$		150		ns	
Timeout (SSI)	$t_m$		20		$\mu$ s	(BiSS = adaptive = T/2)
Rise time	$t_r$	3	11	25	ns	$R_L = 120\Omega, C_L = 100pF$
Fall time	$t_f$	3	11	25	ns	$R_L = 120\Omega, C_L = 100pF$
<b>ABI / UWW</b>						
High level output voltage	$V_{OH}$	2.0	3.0	5.25	$V_{DC}$	$R_L = 120\Omega$
Low level output voltage	$V_{OL}$			0.8	$V_{DC}$	$R_L = 120\Omega$
Output current per channel	$I_{out}$	-1.0		20	mA	overload protection
<b>Sin/Cos</b>						
Output driver current	$I_A$	-1		1	mA	
Analog amplitude	$V_{SS}$	0,9	1	1,2	V	with diff. evaluation
Analog offset	$V_{Off}$	2,3	2,5	2,6	V	
<b>Environment</b>						
Operating temperature	$T_A$	-20	25	85	°C	
Storage temperature	$T_S$	-40		85	°C	
<b>System</b>						
Relative Angular Accuracy			+/- 0,02		°m	depend on mechanic
Absolute Angular Accuracy			+/- 0,1		°m	depend on mechanic

**ESD Warning: Normal handling precautions should be taken to avoid static discharge damage to the sensor.**

## Interface

### Data transfer: SSI Gray-Code

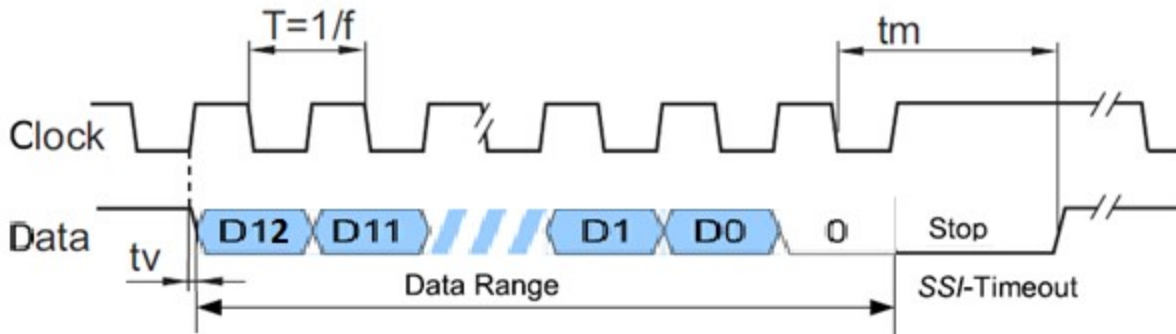

The position data decreases, when the shaft rotates in the direction of clockwise.

Optionally the protocol is available with error bit. Further variations on request.

The resolution is eligible between 13Bit and 18Bit.

### Data transfer: BiSS (C-Mode) Binary-Code

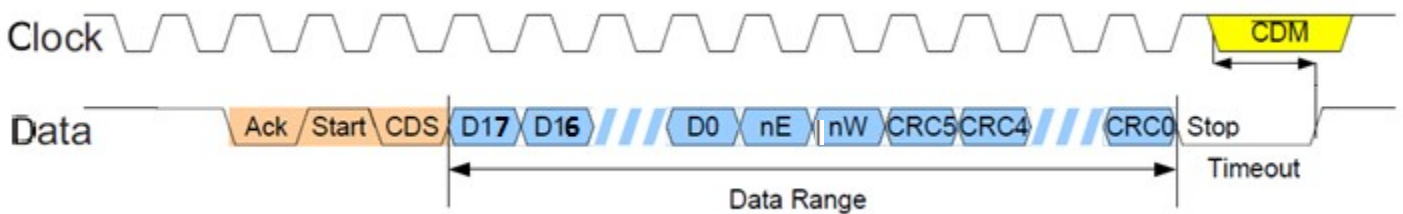

The position data decreases, when the shaft rotates in the direction of clockwise.

Serial interface protocol	Definition
Ack	Acknowledge-Bit
Start	Start-Bit
CDS	Control-Bit
D0 - D17	Position-Data
nE	Low activ error
nW	Low activ warning
CRC0 - CRC5	Cyclic redundancy code
Stop	Stop-Bit
CDM	Control data master

For a detailed description of the protocol, see separate interface specification.

The standard resolution is 18Bit.



## Interface

### Data transfer: SPI

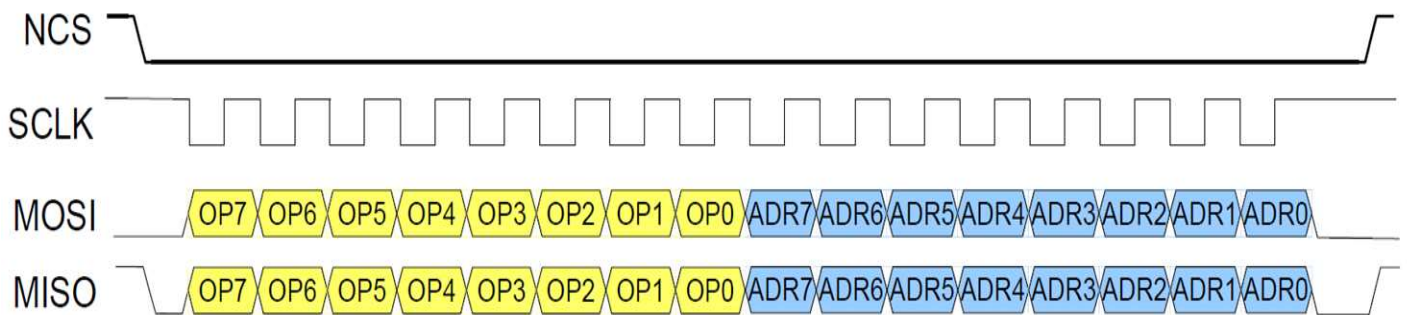

Figure: SPI transmission, using opcode READ REGISTER as an example

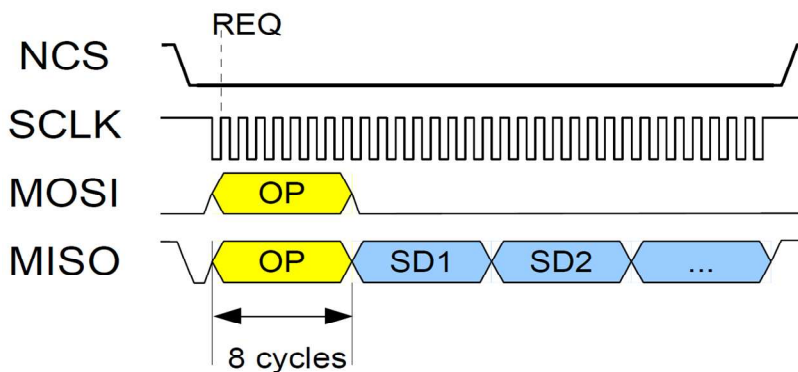

Figure: SPI transmission, READ SENSOR DATA

The Data is sent in packages of 8 bits and with the MSB first. Each data transmission starts with the master sending an opcode to the slave.  
The standard resolution is 18Bit.

Optionally the protocol is available with low idle level on SCLK. Further variations are on request.

The zero position can be set free at every arbitrary position (Preset).

This interface is specially for the direct connection to the micro-controller from the customer.  
It is appropriately for short cable length.

The position data decreases when the shaft rotates in the direction of clockwise.

## Interface

### Incremental

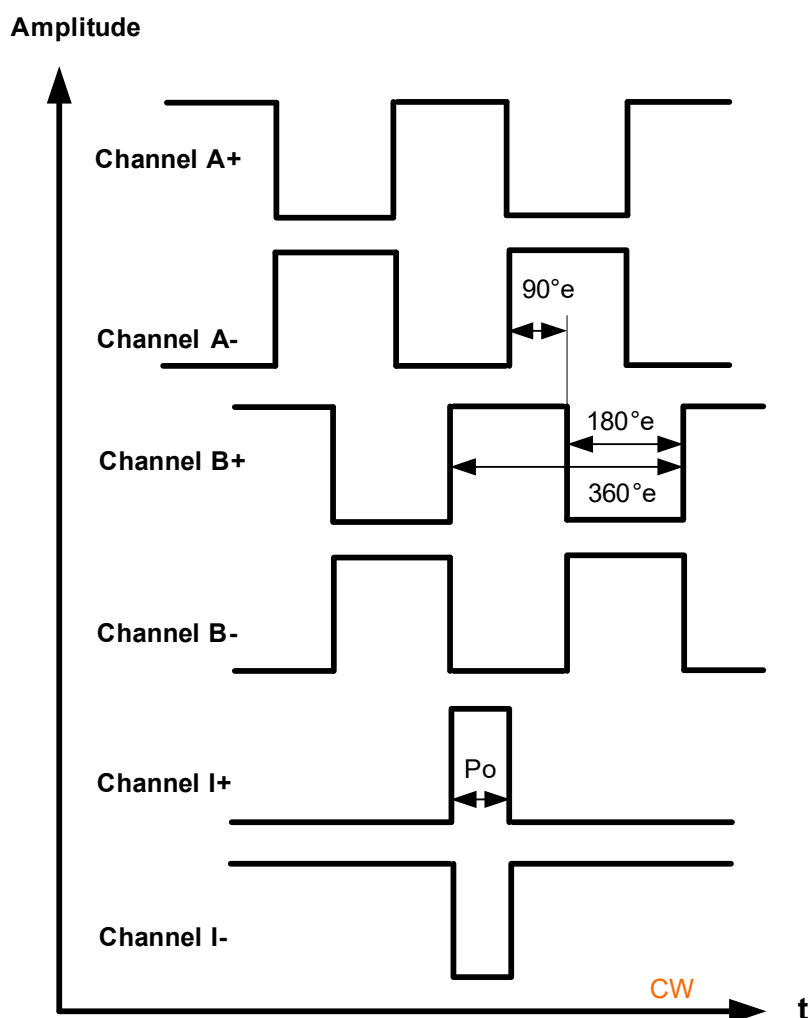

Figure: Incremental interface with differential signals

Optionally the Index pulse I (Po) is available in four different lengths (90°e, 180°e, 270°e and 360°e). The position of the index pulse is in relation to the A/B signals. The position of the Index can be set free (Preset). Further variations are on request.

The resolution of incremental signals ABI can be programmed for each singleturn cycle within a range of 4 to 262,144 edges. That means a resolution from 1 to 65.536 cpr. (1, 2, 3, 4, 5, ..., 65.535, 65.536)

## Interface

### Commutation

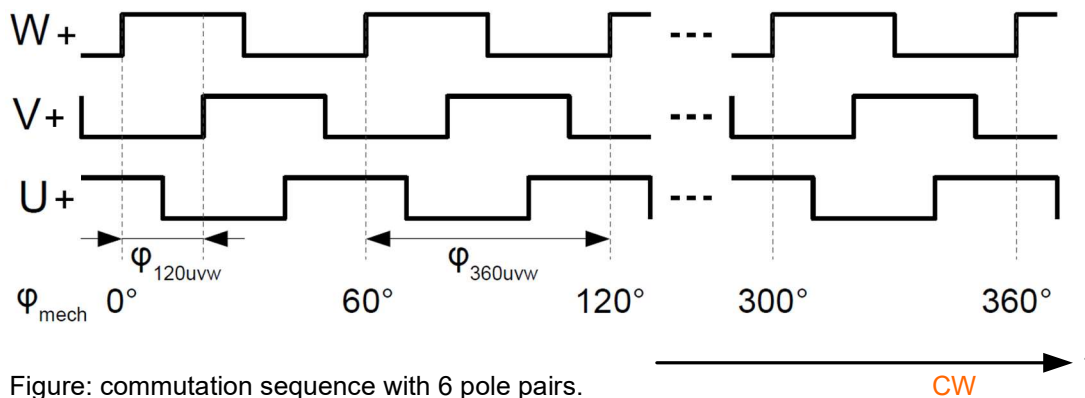

Figure: commutation sequence with 6 pole pairs.

The phaseshift between the commutation signals is  $120^\circ\text{e}$ .

The number of pole pairs for the commutation signals for BLDC motors are available from 1 up to 16. (1, 2, 3, ..., 14, 15, 16 pole pairs)

The start angle for the offset of the winding of the BLDC and the Hall sensor signals can be set free.

## Interface

### Analog

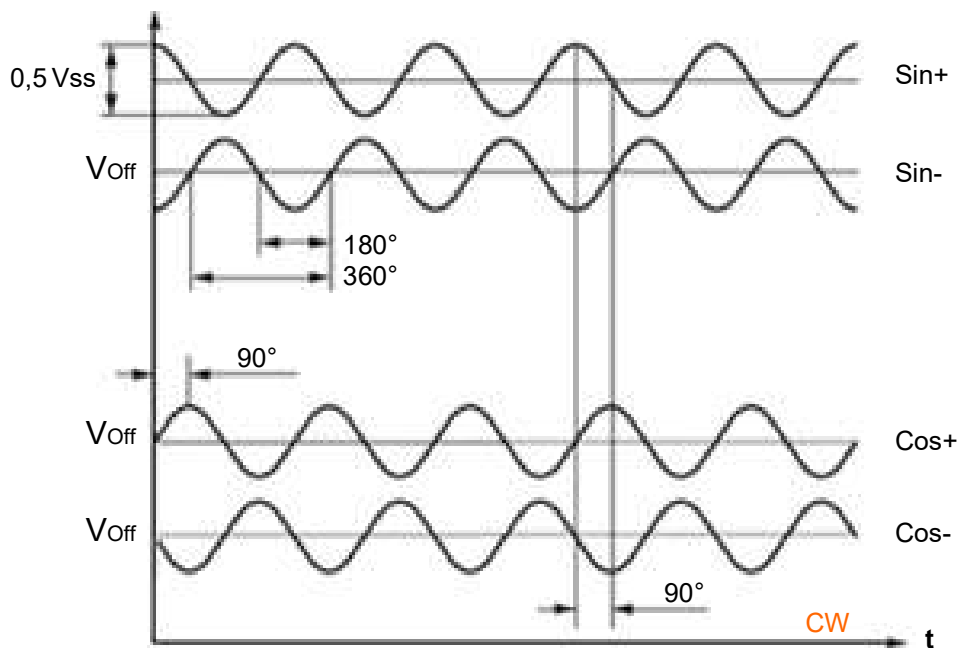

Figure: analog signals

The number of sinus / cosines signals per revolution are depended on the magnet outer diameter:

- AS 25: 32 Sin/Cos
- AS 50: 64 Sin/Cos

As result of the differential evaluation of the both complementary signals Sin+ and Sin- as well as Cos+ and Cos- by using the recommended receiving circuit (see page 9) you will get a Sinus and a Cosinus signal with an amplitude of  $1V_{ss}$ .

## Typical operating circuit \*

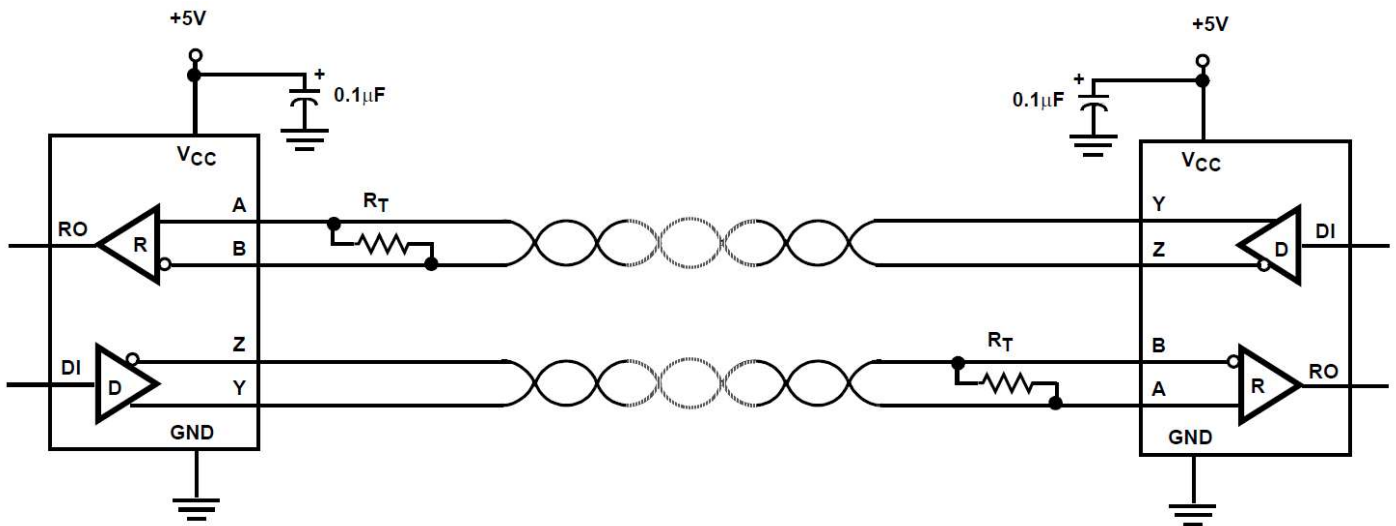

\*  $R_T = 470 \Omega$  (for SSI, BiSS, ABI, UVW)  
 $R_T = 120 \text{ k}\Omega$  (for Sin/Cos)

## Rotation direction

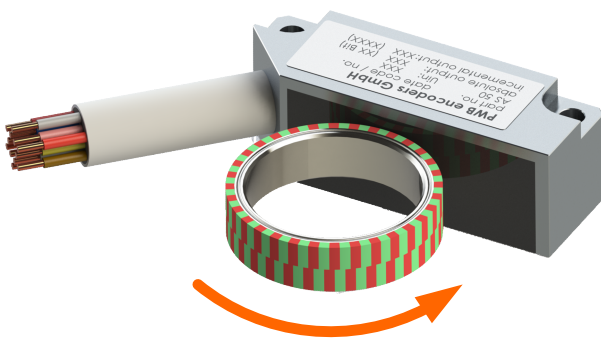

Rotation direction clockwise (CW)

### **PWB encoders GmbH RESTRICTED**

**THIS DOCUMENT AND ANY ASSOCIATED DATA CONTAINS RESTRICTED INFORMATION THAT IS PROPERTY OF PWB encoders GmbH AND MAY NOT BE DISCLOSED OR DUPLICATED FOR OTHERS EXCEPT AS AUTHORIZED BY PWB encoders GmbH**

**INFORMATION CONTAINED IN THIS PUBLICATION MAY BE SUPERSEDED BY UPDATES. IT IS YOUR RESPONSIBILITY TO ENSURE THAT YOUR APPLICATION MEETS WITH YOUR SPECIFICATIONS.**

## Mechanical Notes

Parameter	Value	Tolerance	Unit
Magnet wheel outer diameter $\varnothing$	24.5 / 50.7	$\pm 0.1$	mm
Shaft diameter $\varnothing_w$	10 / 14 / 20 / 39.5 / 44 *	$\pm 0.01$	mm
Permissible radial displacement	0	$\pm 0.1$	mm
Permissible tangential displacement	0	$\pm 0.2$	mm
Permissible axial displacement	0	$\pm 0.3$	mm
Permissible eccentricity	0	$\pm 0.05$	mm
Sensor to magnet wheel distance	0.25	$\pm 0.05$	mm
Moment of inertia of the magnet wheel	20.0	$\pm 1.0$	gmm <sup>2</sup>
Mounting screw size	M3 x 16	-	-
Tightening torque of the screws	25	-5	Ncm
Permissible rotational speed <b>AS 25</b>	12.000	-	rpm
Permissible rotational speed <b>AS 50</b>	6000	-	rpm
Total weight	30	-	g
Protection grade according to DIN 40500	IP65	-	-

\* Customer specific magnet wheels are accomplishable on request.

## Mechanical Positioning

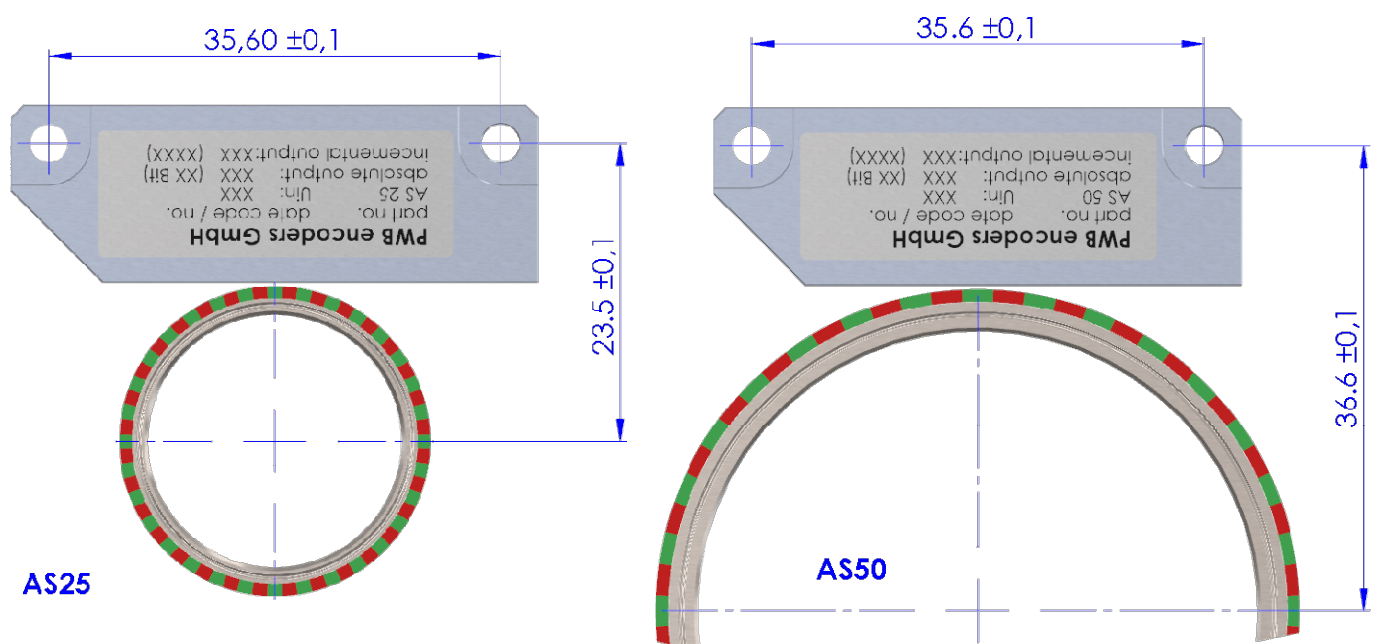



## Mechanical Dimension

### Encoder Head

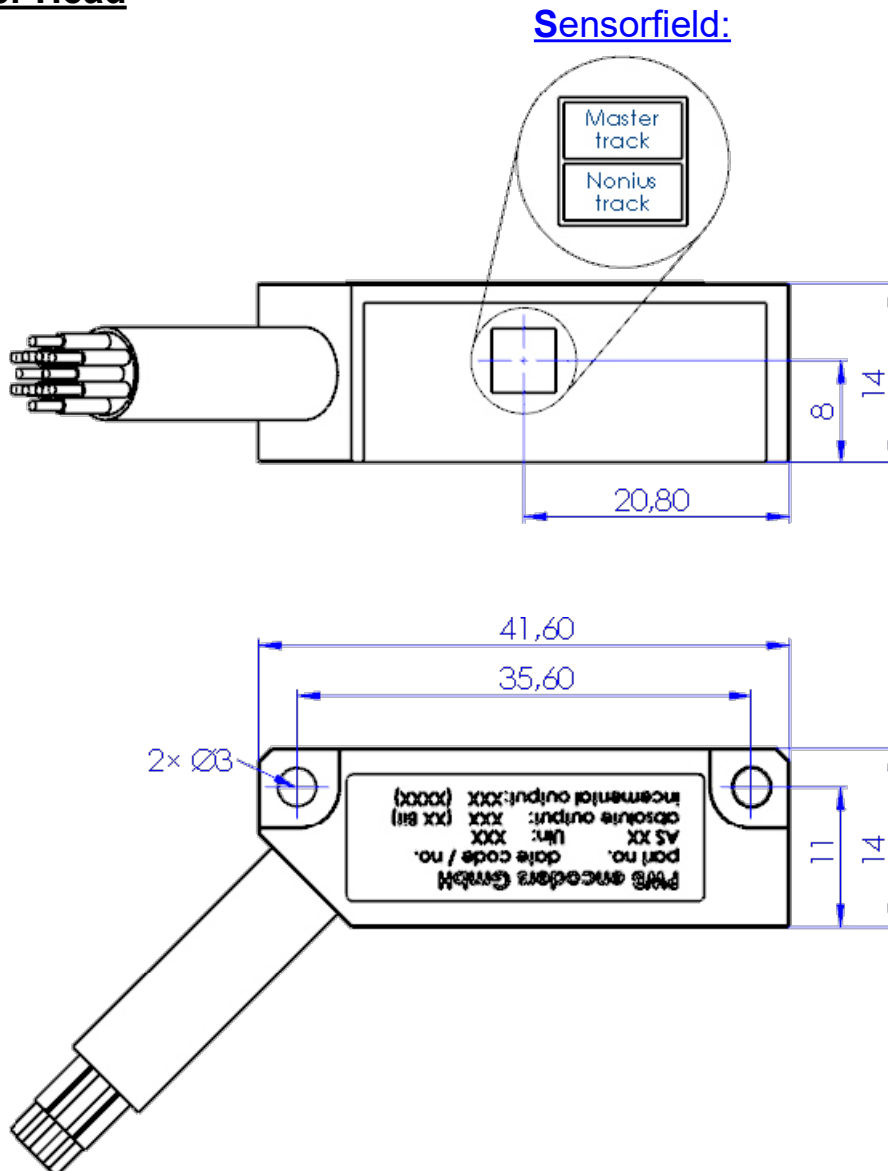

The Encoder head and the accompanying magnet wheel constitute an unit which belongs together. Every Encoder Head is initialised for his own accompanying magnet wheel. He is matched with the magnet wheel and programmed by his first operation by PWB encoders GmbH.

Don't mix up this combination with other ones.

If you exchange the magnet wheel, it may be in function, but the values at the datasheet couldn't guarantee.

Exchange between different magnet wheel sizes are not possible.

## Magnet wheel options for AS25

Screwed Version:  
103603

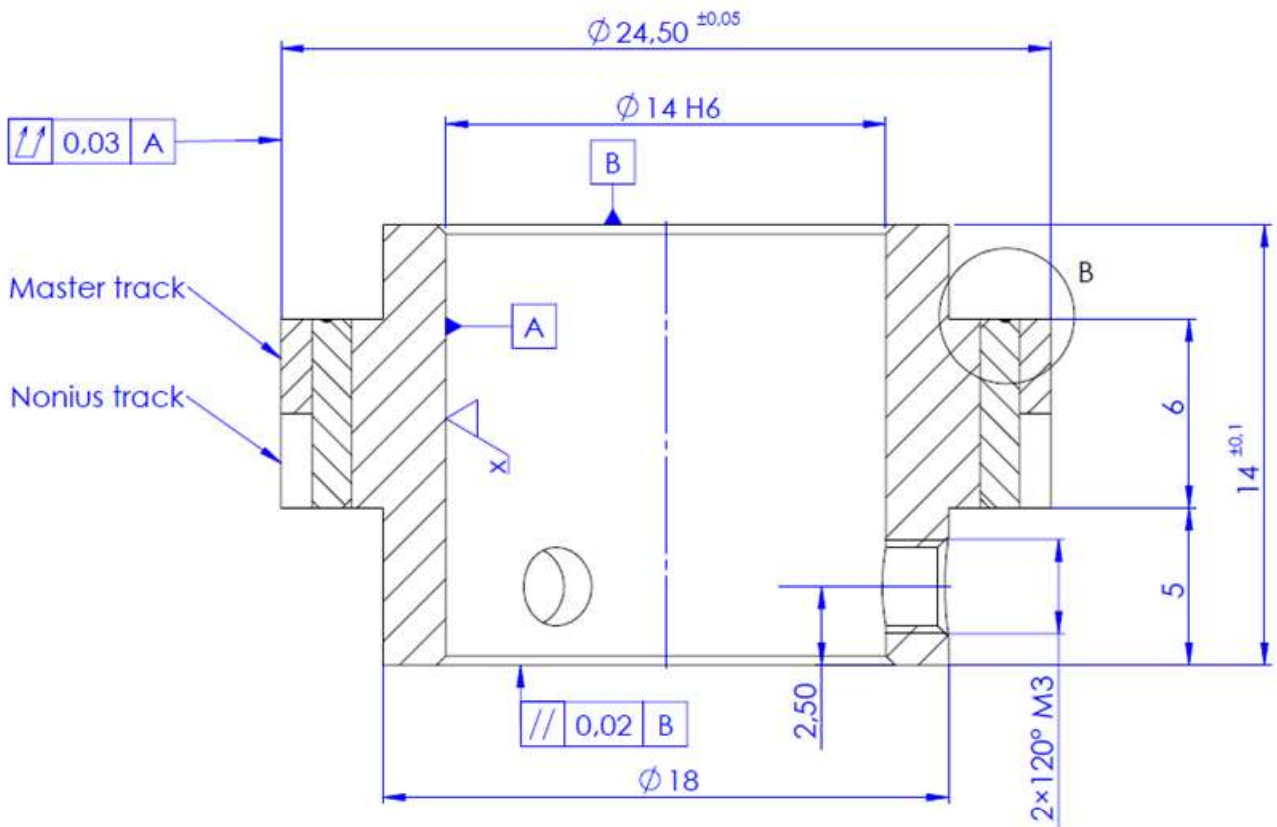

unbemaßte Fasen  $0,3 \times 45^\circ$

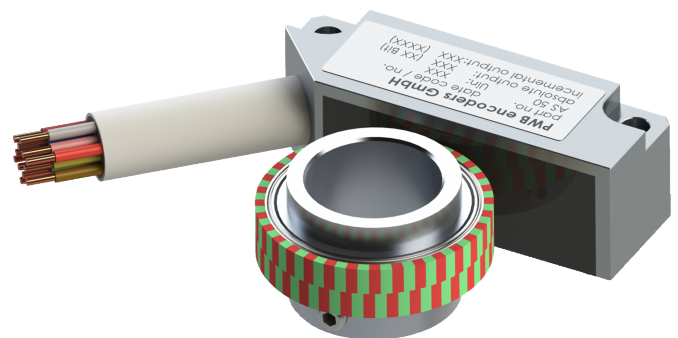
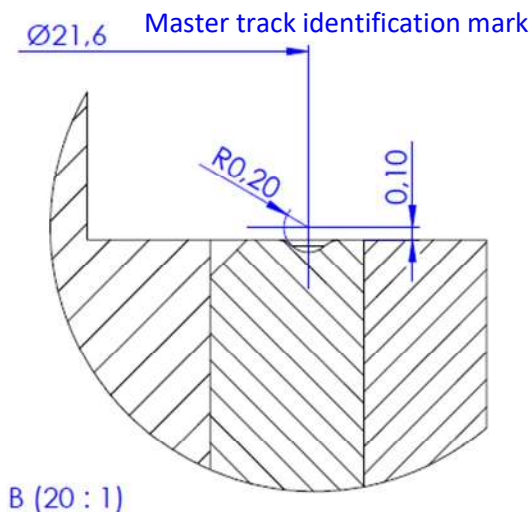

## Magnet wheel options for AS25

Press fit version:  
102417

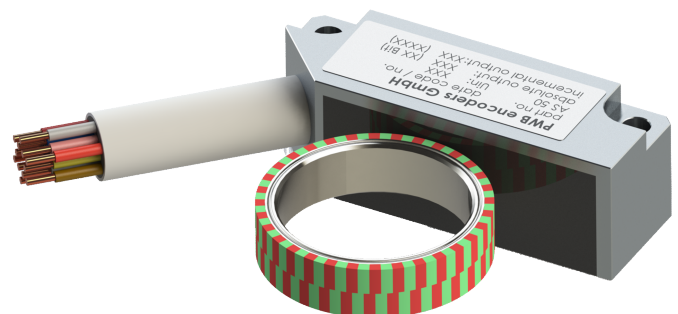
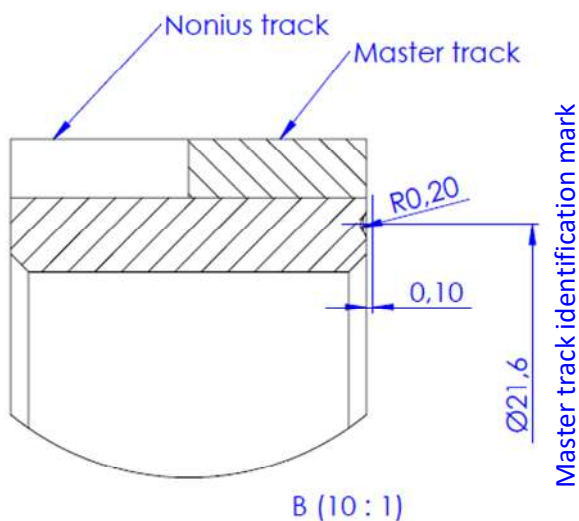
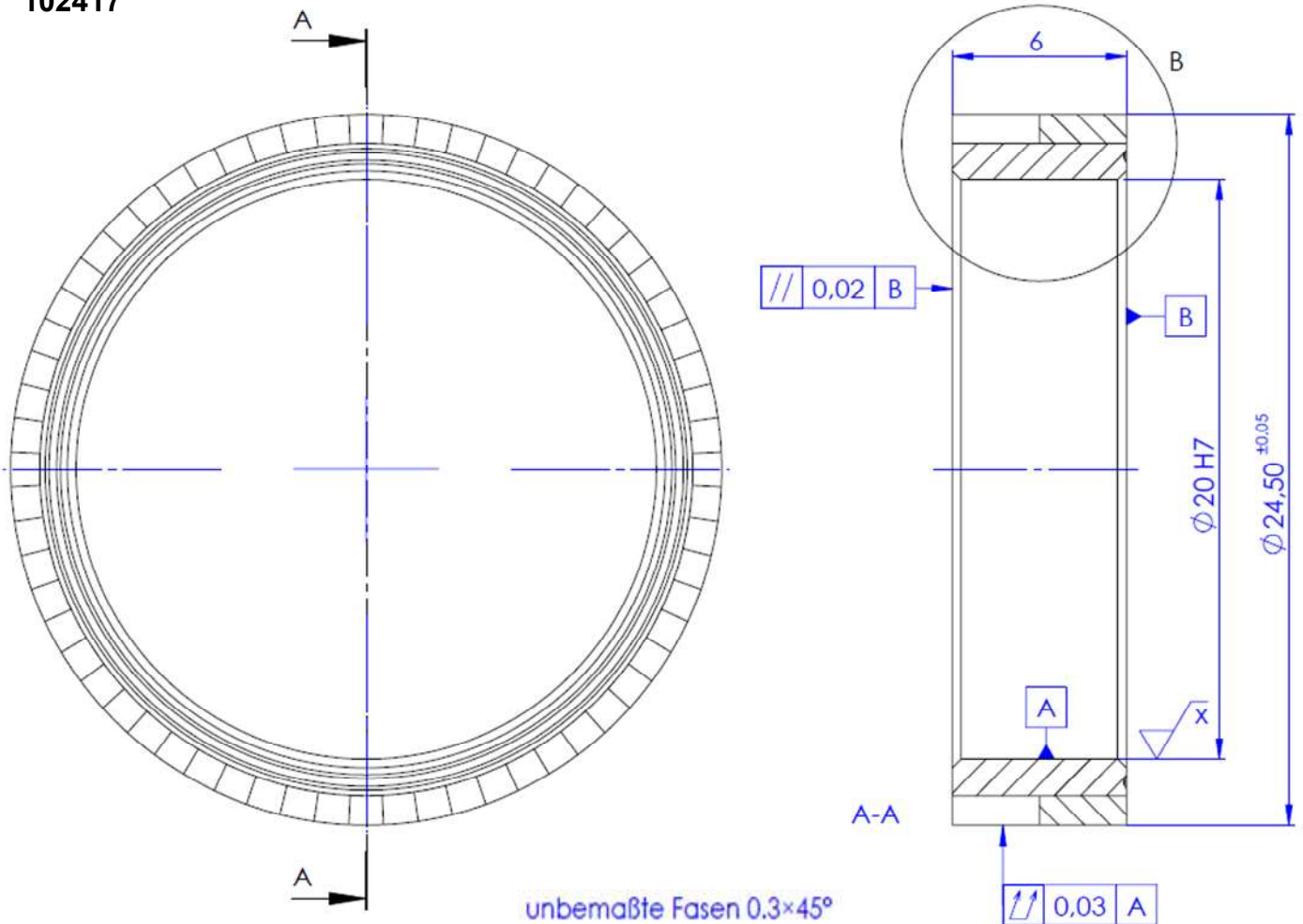

## Magnet wheel options AS50

Screwed Version:  
103606

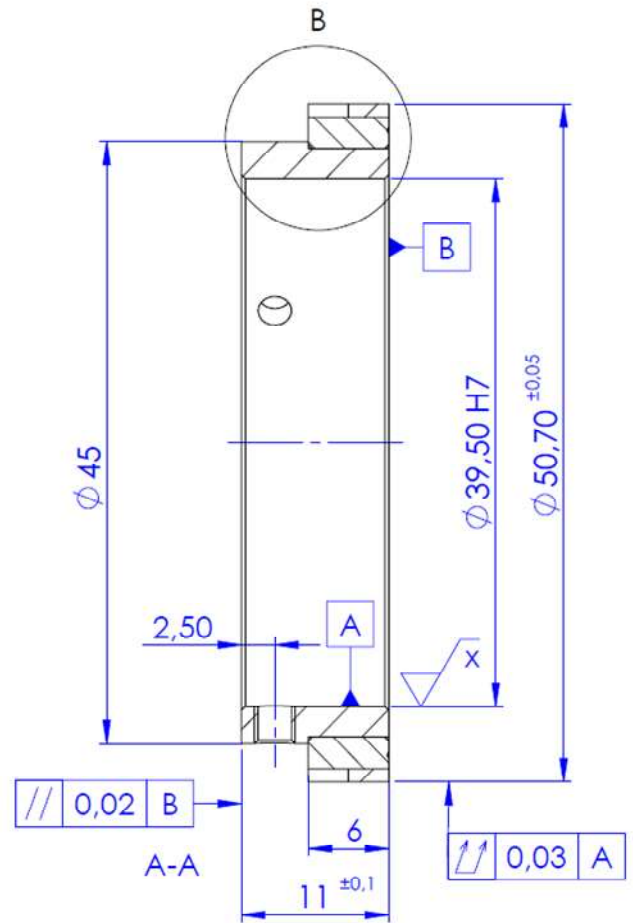
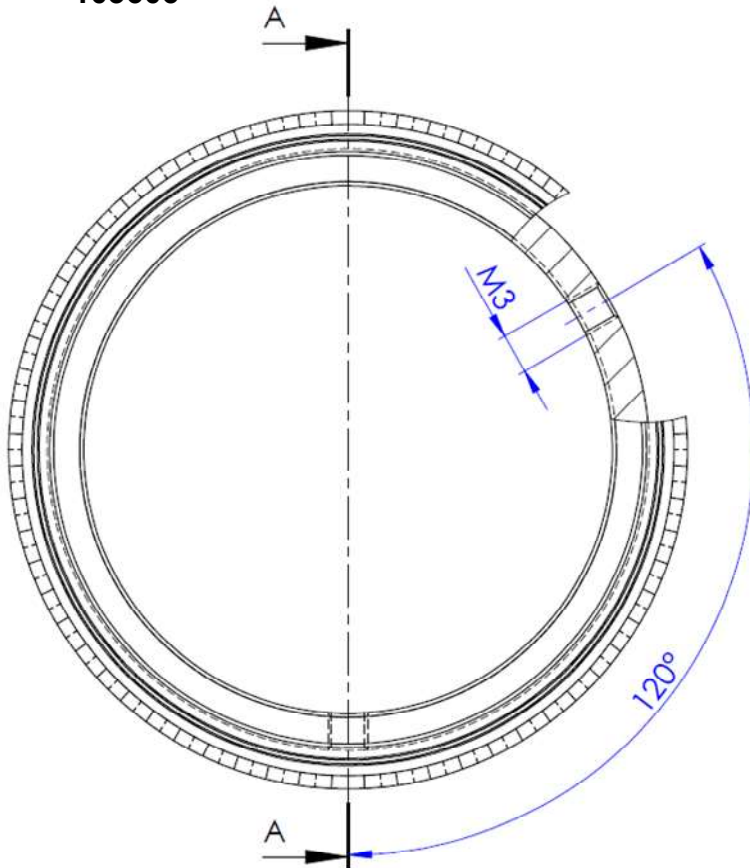

unbemaßte Fasen  $0,3 \times 45^\circ$  Nonius track Master track

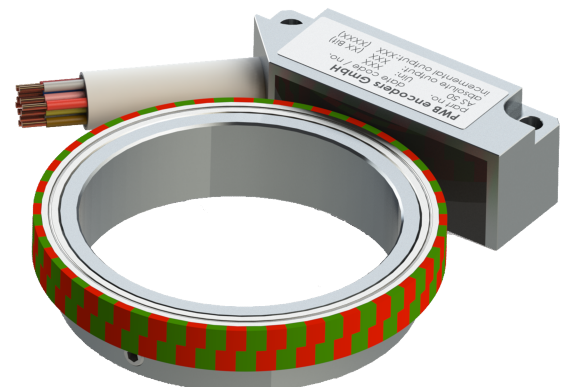
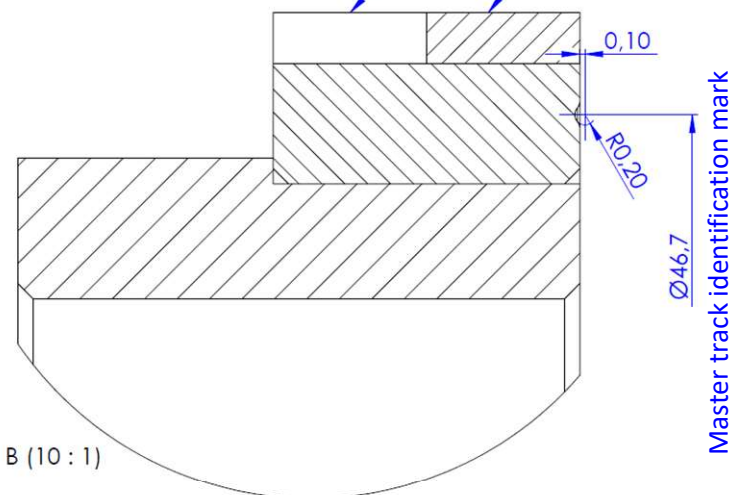



## Magnet wheel options AS50

Press fit version:  
103198

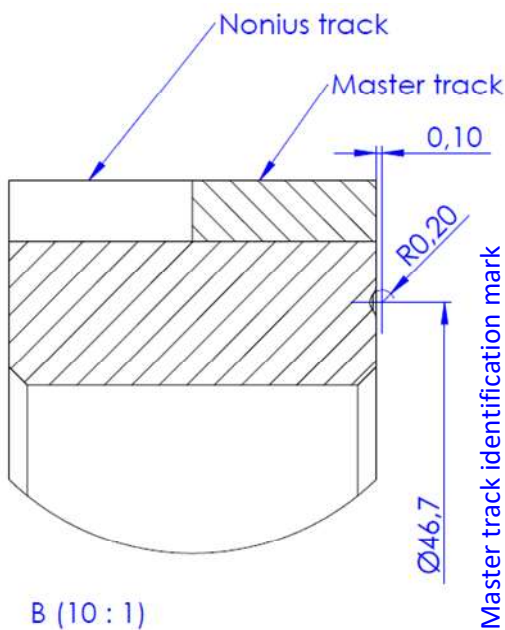
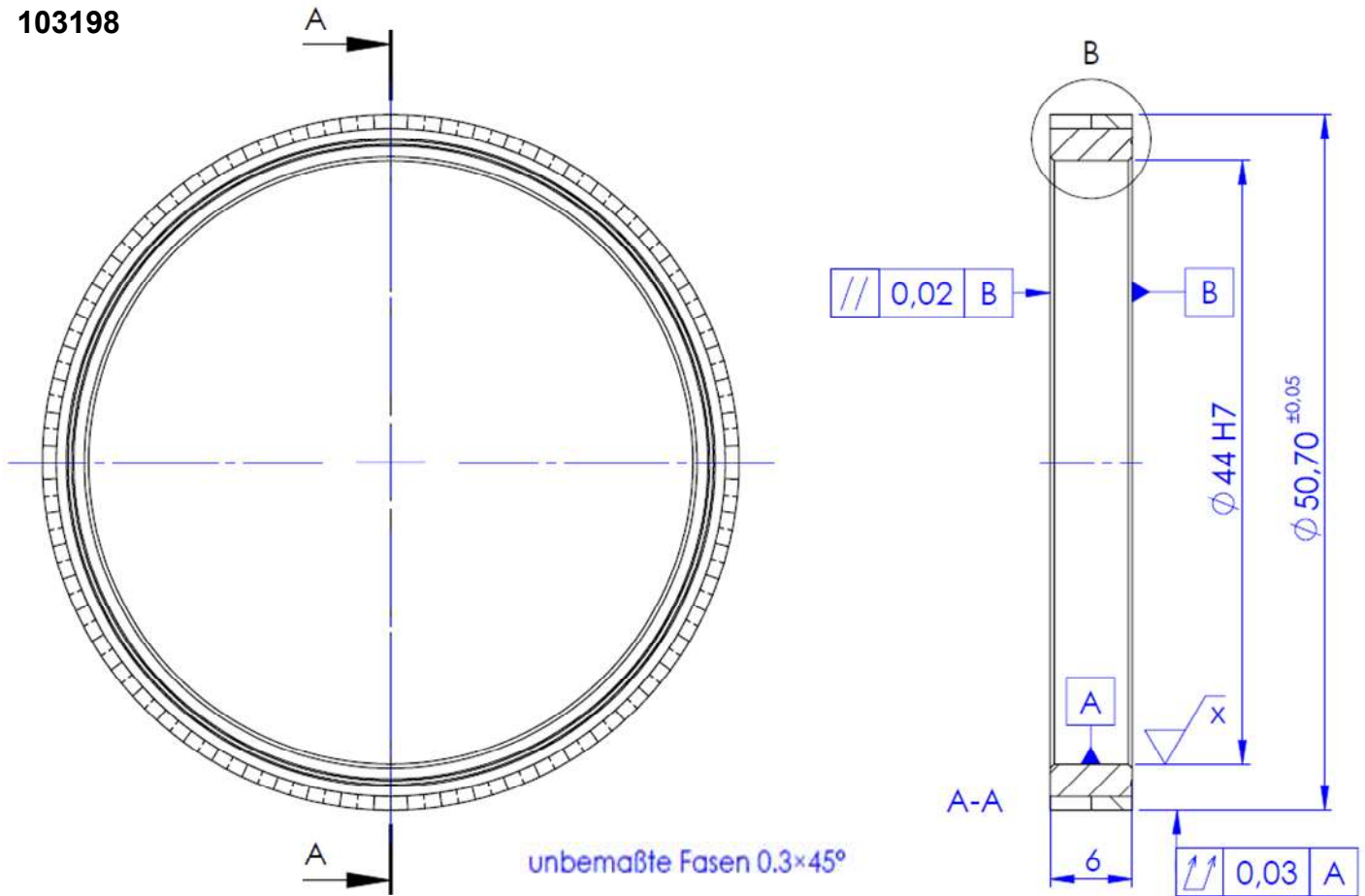

## Terminal assignment

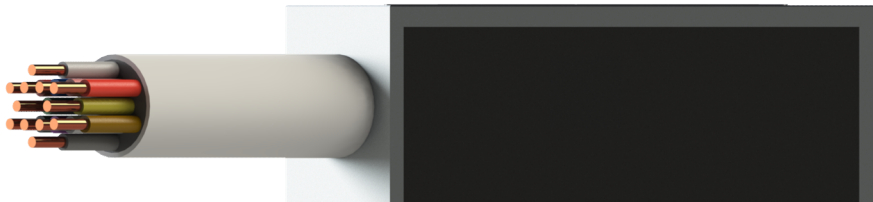

### **Cable:**

data transmission cable  
6 X 2 x 0,14 mm, LiYCY  
shielded, twisted-pair  
outer diameter: 7.1 mm  
flame retardant to VDE 0482

Cable and wire stripped on customer side

## Pin-out description

		<i>Signal description</i>				<i>cable</i>	
SPI	SSI, BiSS	ABI	UVW	Sin/Cos	Supply	color of wire	
					GND	blue	
					UB	red	
		A+	U+	Sin+		green	
		A-	U-	Sin-		yellow	
		B+	V+			brown	
		B-	V-			white	
		I+	W+	Cos+		black	
		I-	W-	Cos-		purple	
MISO	Da+					pink	
MOSI	Da-					grey	
SCLK	Cl+					blue/red	
NCS	Cl-					pink/grey	

(Optionally with error signal)



## Ordering information

Ordering code:

### AS 25 - 10 - SSI 18 - ABI 1024 - 5 - 1,0 - S

Mag. Wheel Diameter	Shaft Diameter	Interface Absolute	Resolution Absolute	Interface Incremental	Resolution Incremental	Supply Voltage	Cable Length	Encoder Option
16: -	-	SSI ->	13: 13 Bit 18: 18 Bit	ABI ->	1 cpr ... cpr 1024 cpr ..... cpr 65536 cpr	05: 5V 12: 8-30V* 24: 8-30V**	0.5 m 1.0 m 2.0 m 3.5 m ... m	S: Standard E: Extended
25: 24.5mm ->	10 mm 14 mm 20 mm	BiSS ->	18: 18 Bit	UVW ->	1 pp ... pp 16 pp			
50: 50.7mm ->	39,5 mm 44 mm	SPI ->	18: 18 Bit	SIN ->	32 sin (AS25) 64 sin (AS50)			

Note:

\* TTL output

\*\* HTL output

The incremental interface and the absolute interface are chosen freely in combination.

**The encoder must be calibrated during initial commissioning.**

### IMPORTANT NOTICE

The guarantee will be voided by misuse, accident, modification, unsuitable physical or operating environment, operation in other than the specified operating environment, or failure caused by a product for which **PWB encoders GmbH** is not responsible.

**PWB encoders GmbH** reserves the right to make corrections, modifications, enhancements, improvements, and other changes to its products and services also datasheets at any time.

## Available accessories



Art. Nr.: 106288: Assembly Tool for AS25  
Thickness 5mm  
For the magnet wheels as press fit version  
with max. shaft diameter 20mm

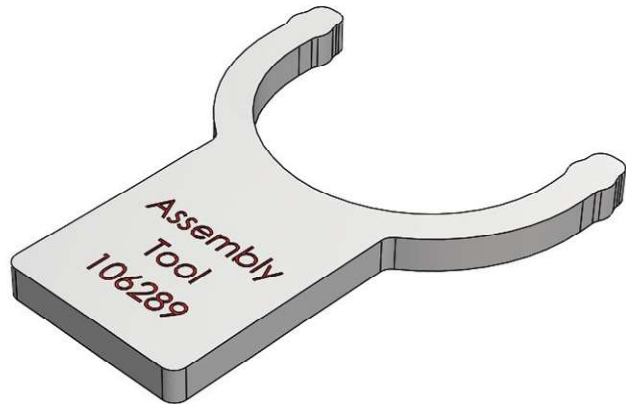

Art. Nr. 106289: Assembly Tool for AS50  
Thickness 5mm  
For the magnet wheels as press fit version  
with max. shaft diameter 44mm

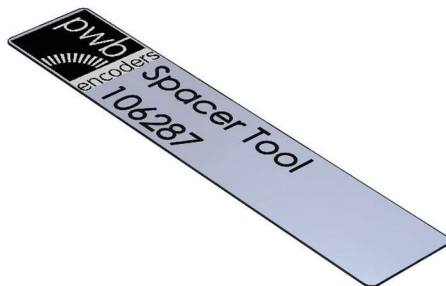

Spacer Tool for AS25 and AS50  
Thickness 0,2mm

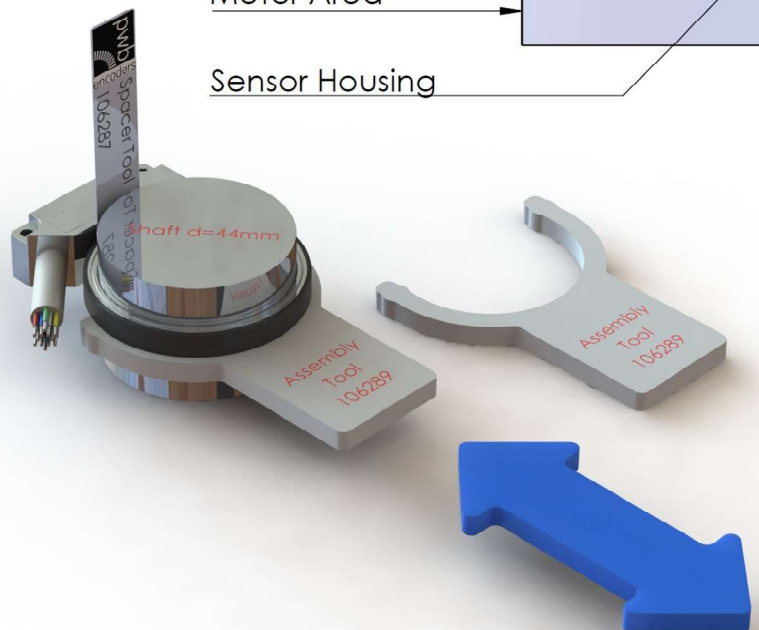
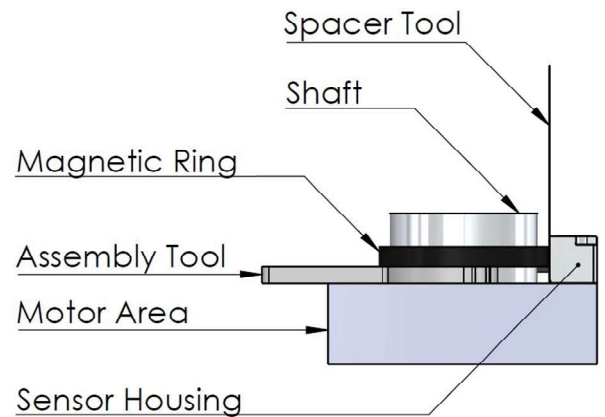

## MOUNTING INSTRUCTION

1

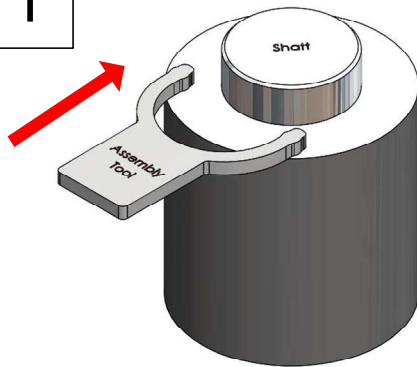

Set the Assembly Tool onto the motor

2

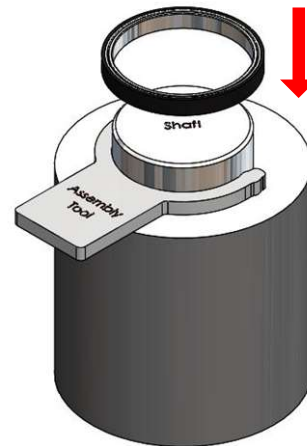

Put the magnet wheel onto the motor shaft

3

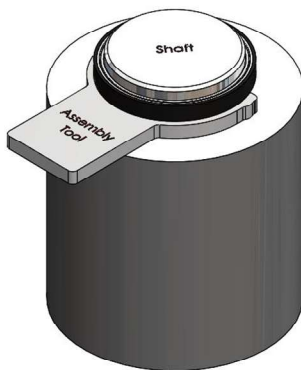

The magnet wheel and the Assembly Tool must lie flat

4

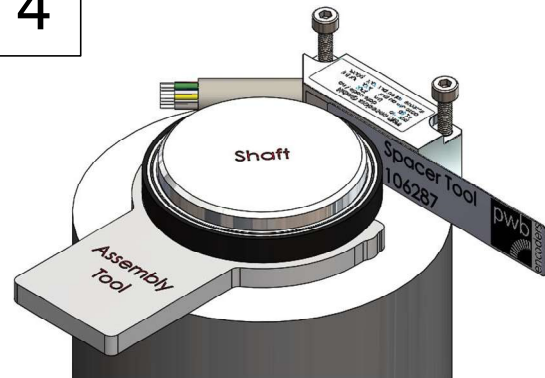

Set the Spacer Tool between the magnet wheel and the sensor head

5

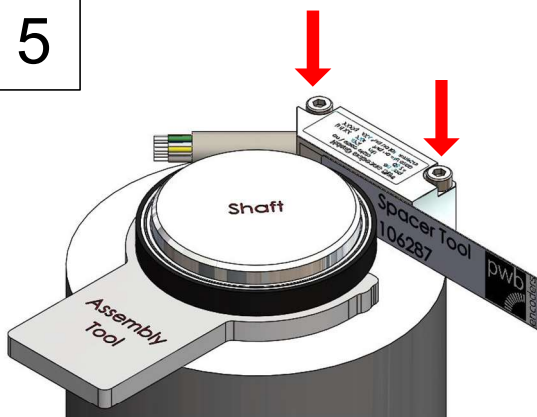

Tighten the screws

6

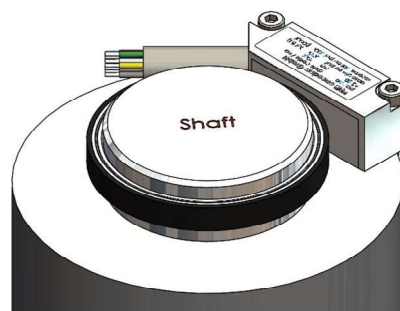

Remove the Spacer Tool and the Assembly Tool