

Absolute / Incremental Singleturn Encoder 18 Bit

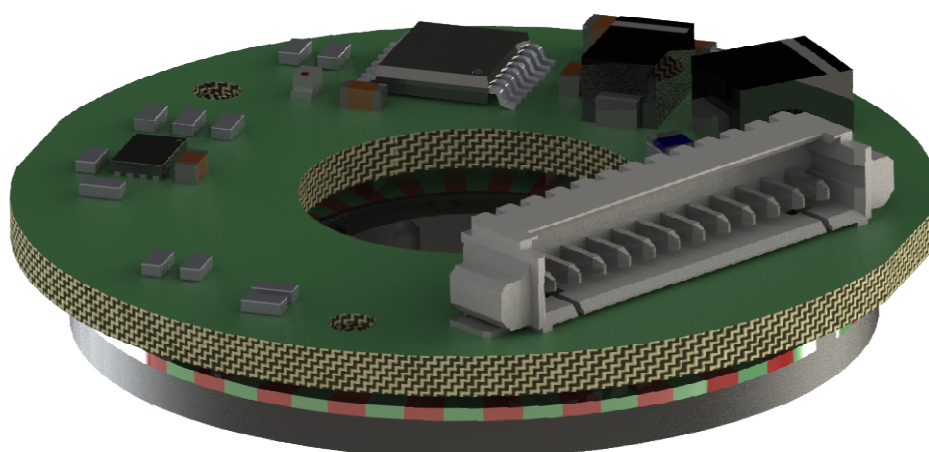

**PWB encoders GmbH
Am Goldberg 2
D-99817 Eisenach
Germany
Phone: +49 3691 72580-0
Fax: +49 3691 72580-29**

**info@pwb-encoders.com
www.pwb-encoders.com**

Description

The **ASA 25** is a high-resolution, multi-functional encoder. It offers a variety of common encoder interfaces. The **ASA 25** generates simultaneously position data as well as speed data. Thus, the encoder is ideal for positioning and rotation speed control.

The **ASA 25** is based on an off-axis hall sensing of a two track magnetic wheel by using the nonius principle. The differential sensing offers the advantage of effectively suppressing homogenous magnetic interferences. This is the reason why static fields don't have a significant influence on output signals.

Features

- Singleturn encoder
- Magnetic sensing
- 2 port output (absolute + incremental simultaneously)
- Interface: SSI (synchron serial interface) (up to 18 Bit)
- BiSS ® (bidirectional serial synchron) (up to 18 Bit)
- SPI (serial peripheral interface) (up to 18 Bit)
- ABI (incremental interface) (up to 65.536 cpr)
- UVW (commutation signals) (up to 16 pole pairs)
- Sin/Cos (analog interface) (32 periods)
- Compact size
- Bearing free
- Operating temperature: -20°C to +85°C
- Compliant EU-directive 2011/65/EU (RoHS)



SPI

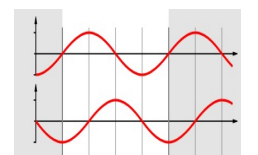
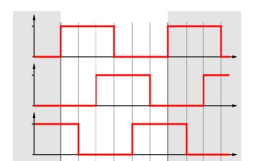
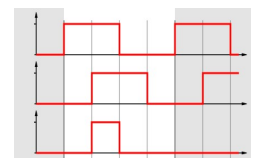

Applications

- Motor feedback
- BLDC motor commutation
- Hollow shaft
- Multi-axis measurement systems

Direction of rotation

Clockwise (CW)
(view from motor to encoder)

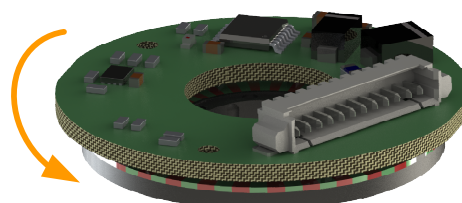

Recommended operating conditions

Electrical characteristics are only effective for the range of the operating temperatures.
Typical values at 25 °C.

Parameter	Symbol	Min.	Typ.	Max.	Unit	Notes
Supply voltage	U_B	4.75	5.0	5.25	V_{DC}	
Supply current	I_{UB}	30	50	80	mA	no load
Reverse polarity protection	U_B	-36		0	V_{DC}	
Start up time	t_T		20		ms	
ESD voltage	U_{ESD}			2	kV	discharged over 1,5k Ω
SSI / BiSS / SPI						
Clock frequency	f	80		10000	kHz	
Scan ratio of T		40	50	60	%	
Time lag	t_v		150		ns	
Monoflop time	t_m		20 + T/2		μ s	
Rise time	t_r	3	11	25	ns	$R_L = 120\Omega, C_L = 100pF$
Fall time	t_f	3	11	25	ns	$R_L = 120\Omega, C_L = 100pF$
ABI / UVW						
High level output voltage	V_{oH}	2.0	3.0	5.25	V_{DC}	$R_L = 120\Omega$
Low level output voltage	V_{oL}			0.8	V_{DC}	$R_L = 120\Omega$
Output current per channel	I_{out}	-1.0		20	mA	overload protection
Sin/Cos						
Output driver current	I_A	-1		1	mA	
Analog amplitude	V_{SS}	0,9	1	1,2	V	with diff. evaluation
Analog offset	V_{Off}	2,3	2,5	2,6	V	
Environment						
Operating temperature	T_A	-20	25	85	° C	
Storage temperature	T_S	-30		100	° C	
System						
Relative Angular Accuracy			+/- 0,02 *		° m	depend on mechanic
Absolute Angular Accuracy			+/- 0,2 *		° m	depend on mechanic

* After calibration with the PWBxC converter box and the related calibration software

ESD Warning: Normal handling precautions should be taken to avoid static discharge damage to the sensor.

Interface

Data transfer: SSI Gray-Code*

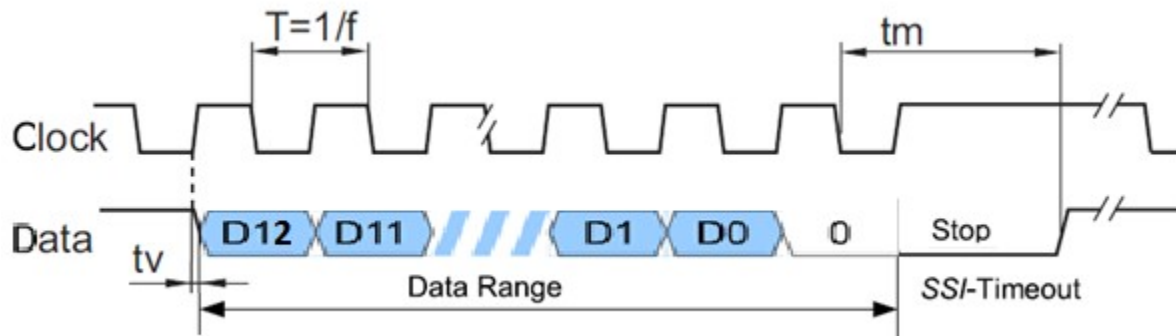

* optionally in binary

Optionally the protocol is available with error bit. Further variations on request.

The resolution is eligible between 13Bit, 18Bit and 19Bit.

The position data increases when the shaft rotates in the direction of clockwise.

Data transfer: BiSS (C-Mode) Binary-Code

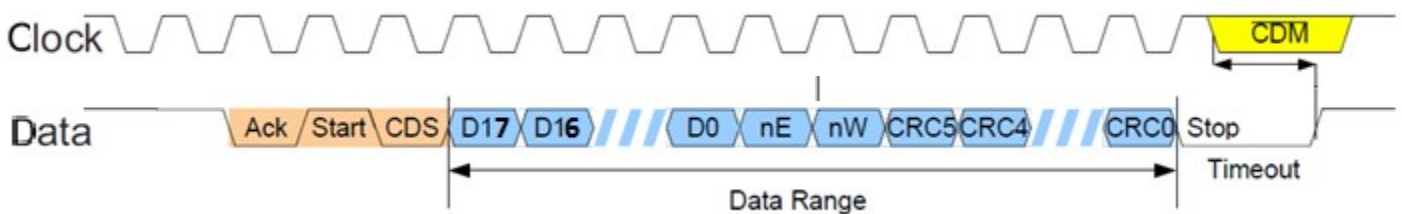

Serial interface protocol	Definition
Ack	Acknowledge-Bit
Start	Start-Bit
CDS	Control-Bit
D0 - D17	Position-Data
nE	Low activ error
nW	Low activ warning
CRC0 - CRC5	Cyclic redundancy code
Stop	Stop-Bit
CDM	Control data master

For a detailed description of the protocol, see separate interface specification.

The position data increases when the shaft rotates in the direction of clockwise.

Interface

Data transfer: SPI

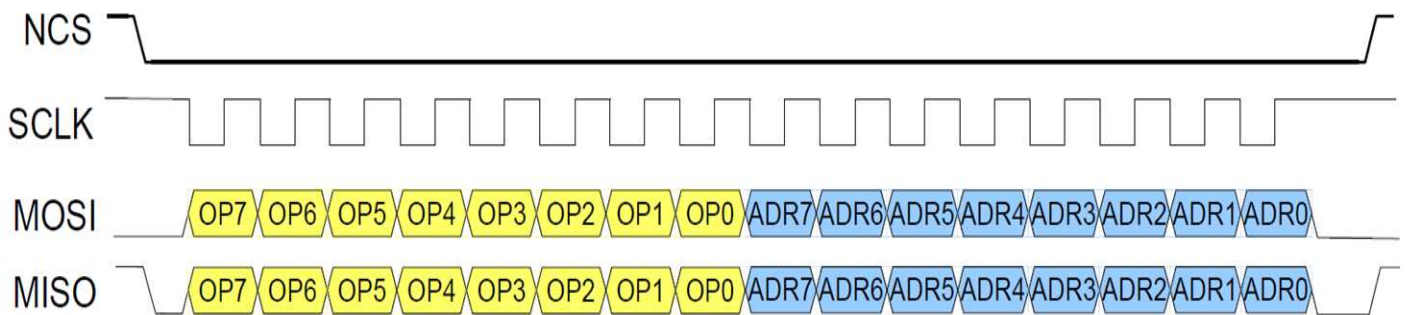

Figure: SPI transmission, using opcode READ REGISTER as an example

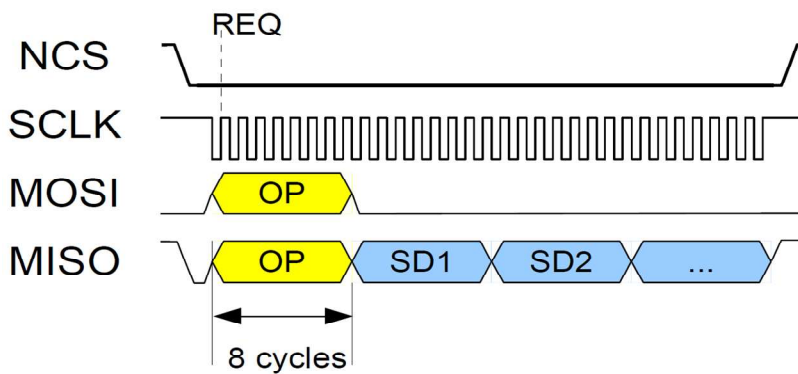

Figure: SPI transmission, READ SENSOR DATA

OPCODE	
0xA6	Read Encoder Position
0x97	Read Encoder Status (Address 0x76 + 0x77)
0xAD	Read Status of the last data transmission

Figure: SPI Opcode

The Data is sent in packages of 8 bits and with the MSB first. Each data transmission starts with the master sending an opcode to the slave.

Optionally the protocol is available with low idle level on SCLK. Further variations are on request.

The zero position can be set free at every arbitrary position (Preset).

This interface is specially for the direct connection to the micro-controller from the customer. It is appropriately for short cable length.

The position data increases when the shaft rotates in the direction of clockwise.

Interface

Incremental

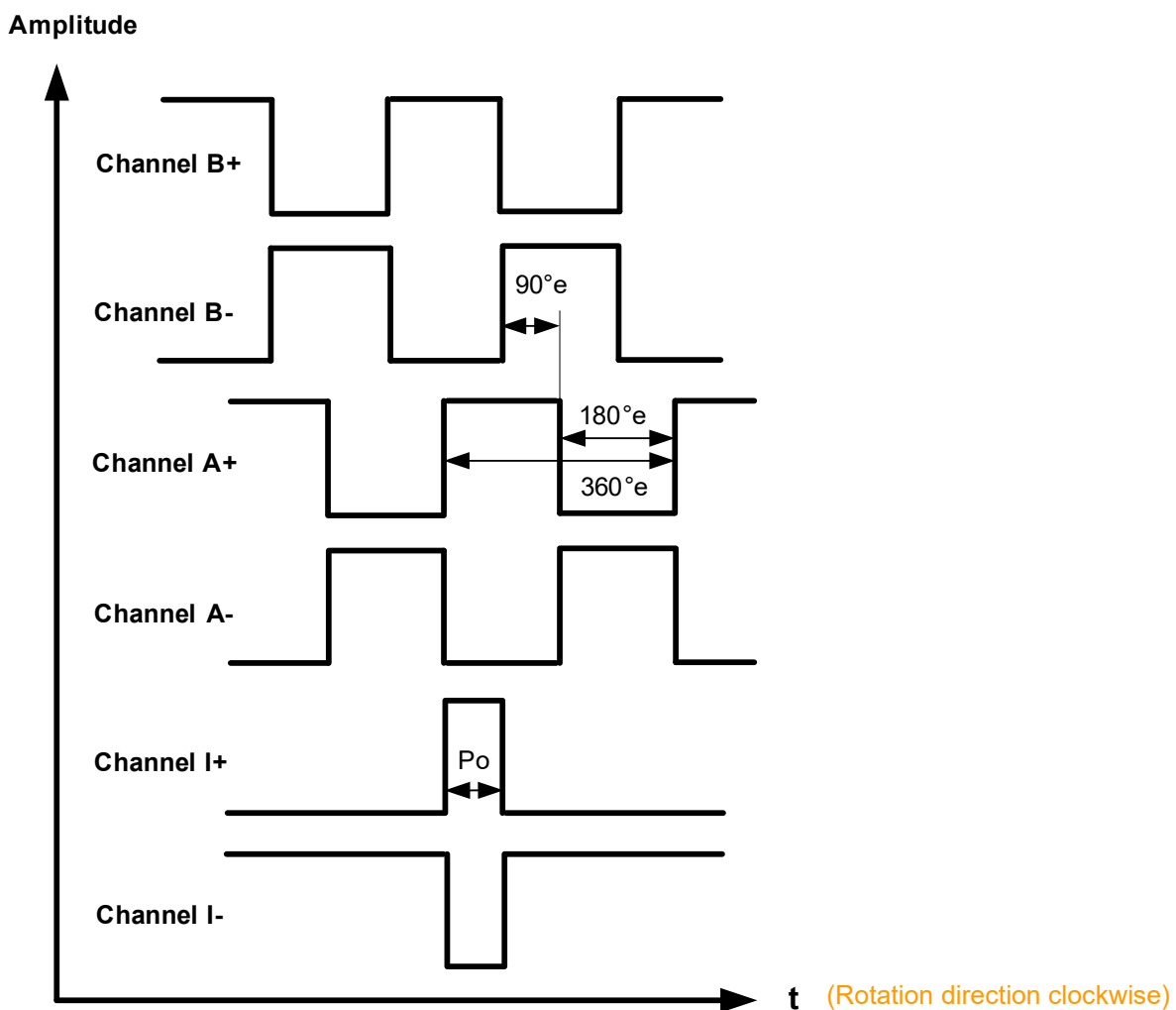

Figure: Incremental interface with differential signals

Optionally the Index pulse I (Po) is available in four different lengths (90°e, 180°e, 270°e and 360°e). The position of the index pulse is in relation to the A/B signals. The position of the Index can be set free (Preset). Further variations are on request.

The resolution of incremental signals ABI can be programmed for each singleturn cycle within a range of 4 to 262,144 edges. That means a resolution from 1 to 65.536 cpr. (1, 2, 3, 4, 5, ..., 65.535, 65.536)

Interface

Commutation

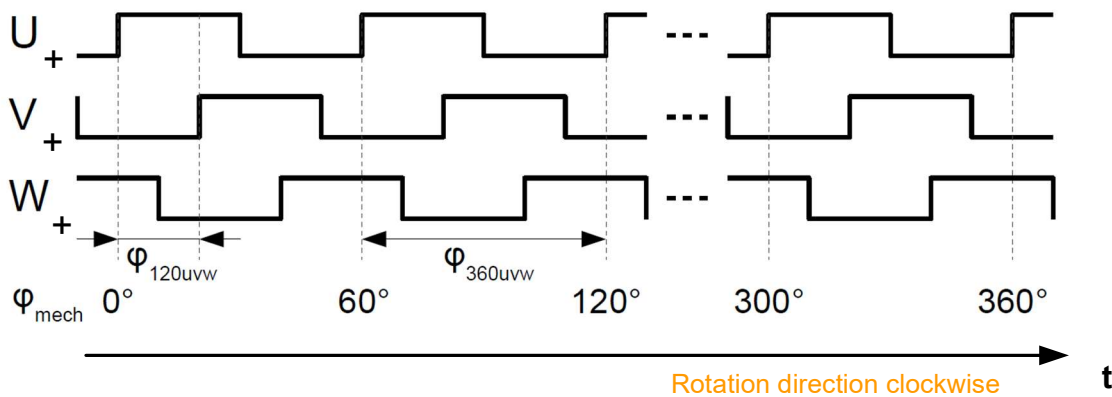

Figure: commutation sequence with 6 pole pairs.

The phaseshift between the commutation signals is 120°e.

The number of pole pairs for the commutation signals for BLDC motors are available from 1 up to 16. (1, 2, 3, ..., 14, 15, 16 pole pairs)

The start angle for the offset of the winding of the BLDC and the Hall sensor signals can be set free.

Connector

Molex connector, grid 1.25mm, angled, SMD
53261-1271

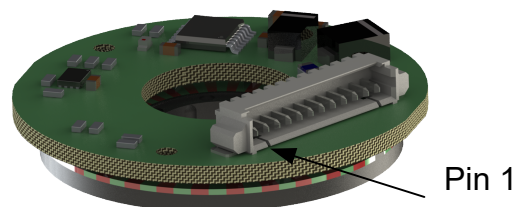

PWB encoders GmbH RESTRICTED

THIS DOCUMENT AND ANY ASSOCIATED DATA CONTAINS RESTRICTED INFORMATION THAT IS PROPERTY OF PWB encoders GmbH AND MAY NOT BE DISCLOSED OR DUPLICATED FOR OTHERS EXCEPT AS AUTHORIZED BY PWB encoders GmbH

INFORMATION CONTAINED IN THIS PUBLICATION MAY BE SUPERSEDED BY UPDATES. IT IS YOUR RESPONSIBILITY TO ENSURE THAT YOUR APPLICATION MEETS WITH YOUR SPECIFICATIONS.

Interface

Analog

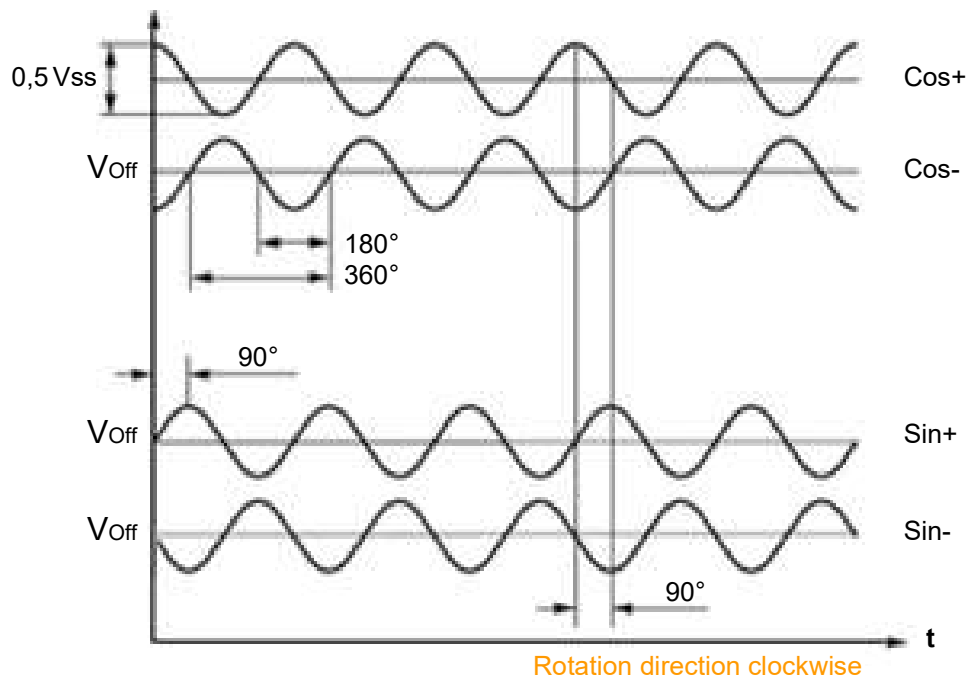

As result of the differential evaluation of the both complementary signals Sin+ and Sin- as well as Cos+ and Cos- by using the recommended receiving circuit you will get a Sinus and a Cosinus signal with an amplitude of 1Vss.

Typical operating circuit *

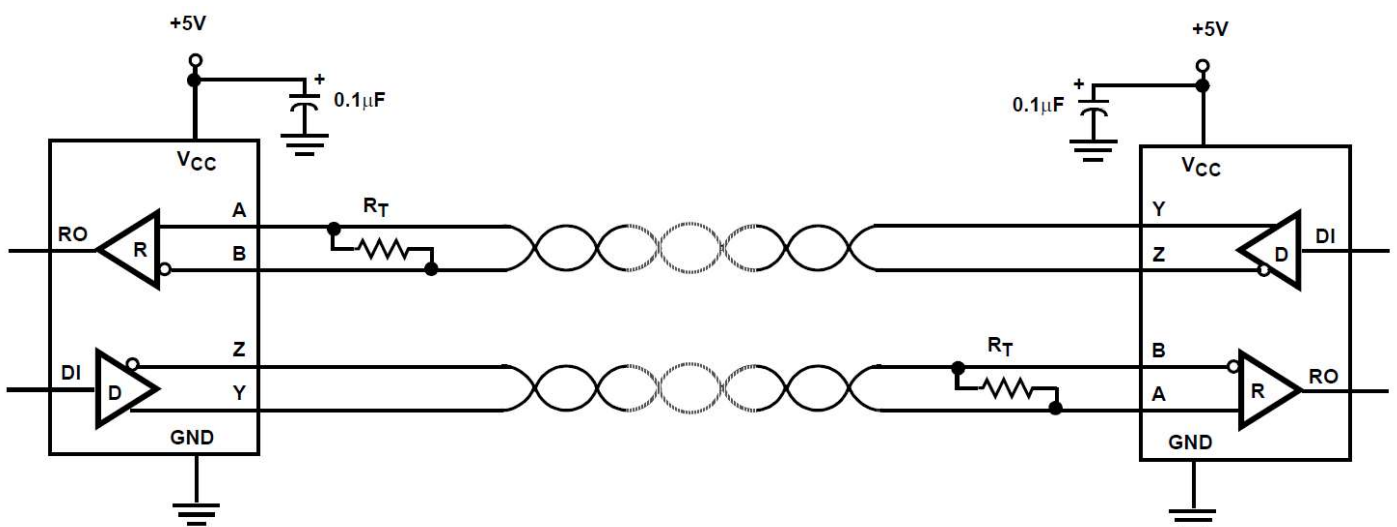

* $R_T = 470 \Omega$ (for SSI, BiSS, ABI, UVW)
 $R_T = 120 \text{ k}\Omega$ (for Sin/Cos)

Mechanical Notes

Parameter	Value	Tolerance	Unit
Magnet wheel outer diameter \varnothing	30.0	+0.1 / -0.2	mm
Motor shaft diameter \varnothing	11.0	± 0.025	mm
Permissible radial displacement	0	± 0.2	mm
Permissible tangential displacement	0	± 0.2	mm
Permissible axial displacement	0	± 0.1	mm
Permissible excentricity	0	± 0.05	mm
Sensor to magnet wheel distance	0.25	± 0.05	mm
Moment of inertia of the magnet wheel	10.0	± 1.0	gmm ²
Mounting screw size	M 1.8	-	-
Tightening torque of the screws	30	-5	Ncm
Permissible rotational speed ASA 25	12.000	-	rpm
Total weight	30	-	g
Protection grade according to DIN 40500	IP00	-	-

Mechanical Dimension

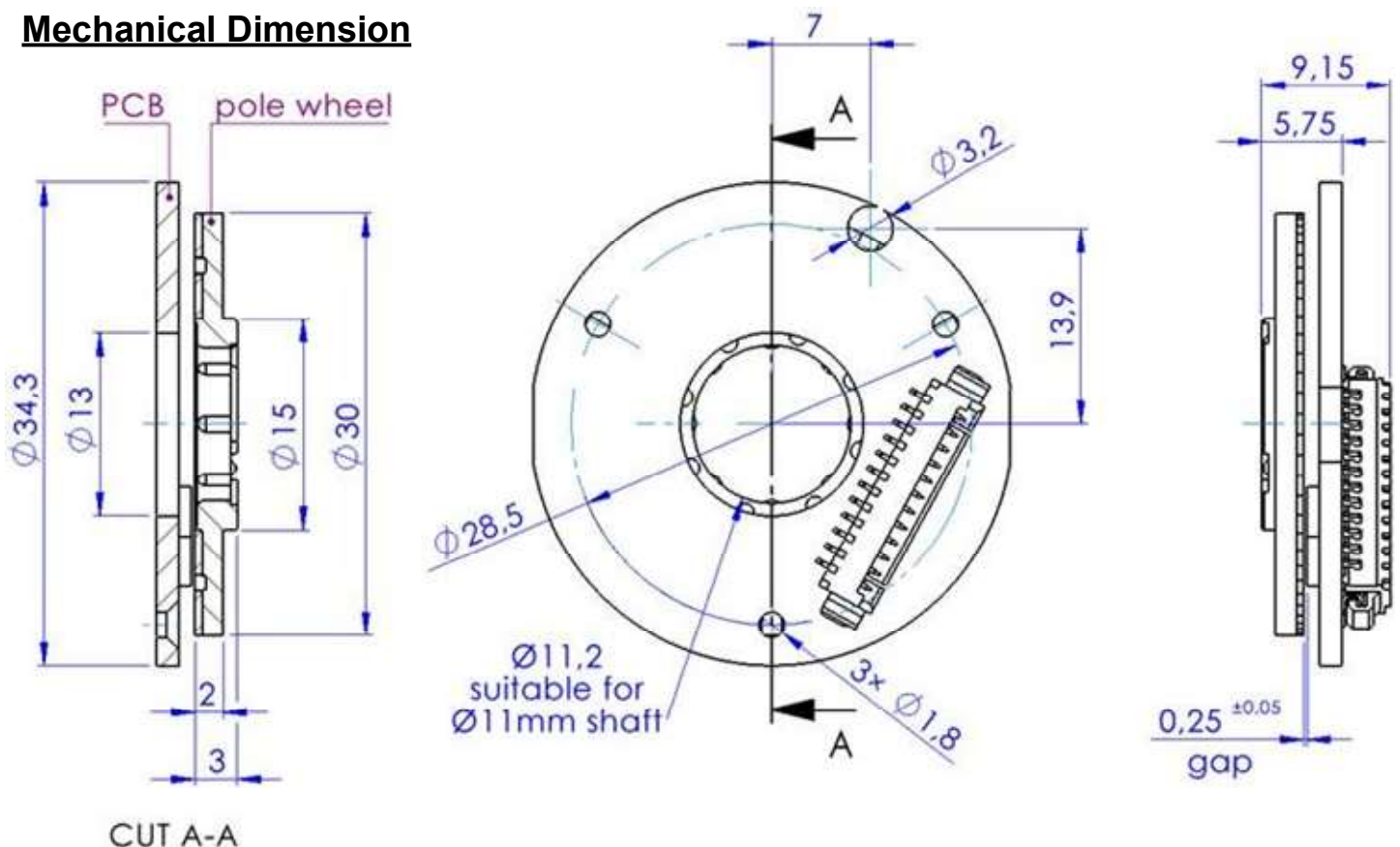

Magnet wheel:

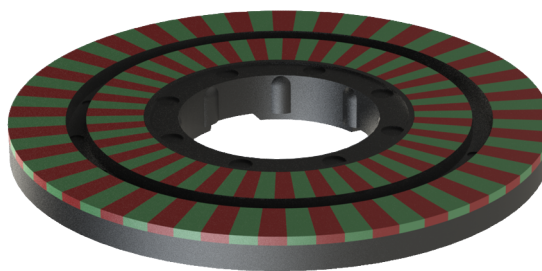
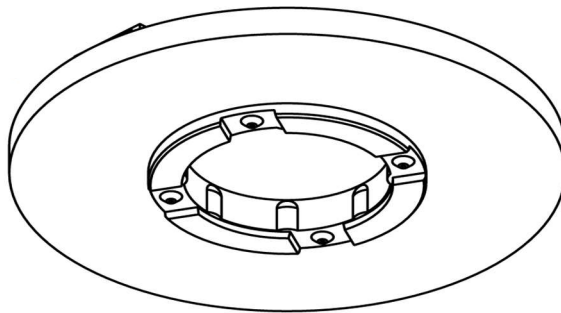
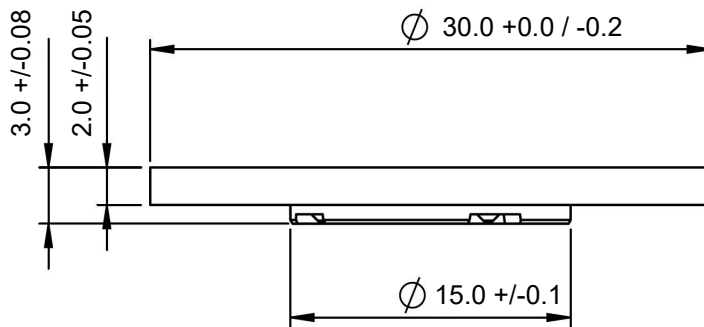

PCB:

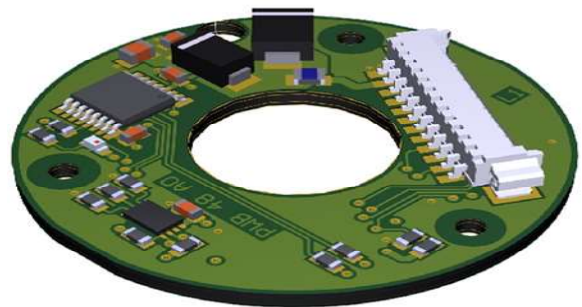

The encoder must be calibrated during initial commissioning.

IMPORTANT NOTICE

The guarantee will be voided by misuse, accident, modification, unsuitable physical or operating environment, operation in other than the specified operating environment, or failure caused by a product for which **PWB encoders GmbH** is not responsible.

PWB encoders GmbH reserves the right to make corrections, modifications, enhancements, improvements, and other changes to its products and services also datasheets at any time.

Ordering information

Ordering code:

ASA25 - 11 - SSI 18 - ABI 1024 - 05 - 0,0 - S

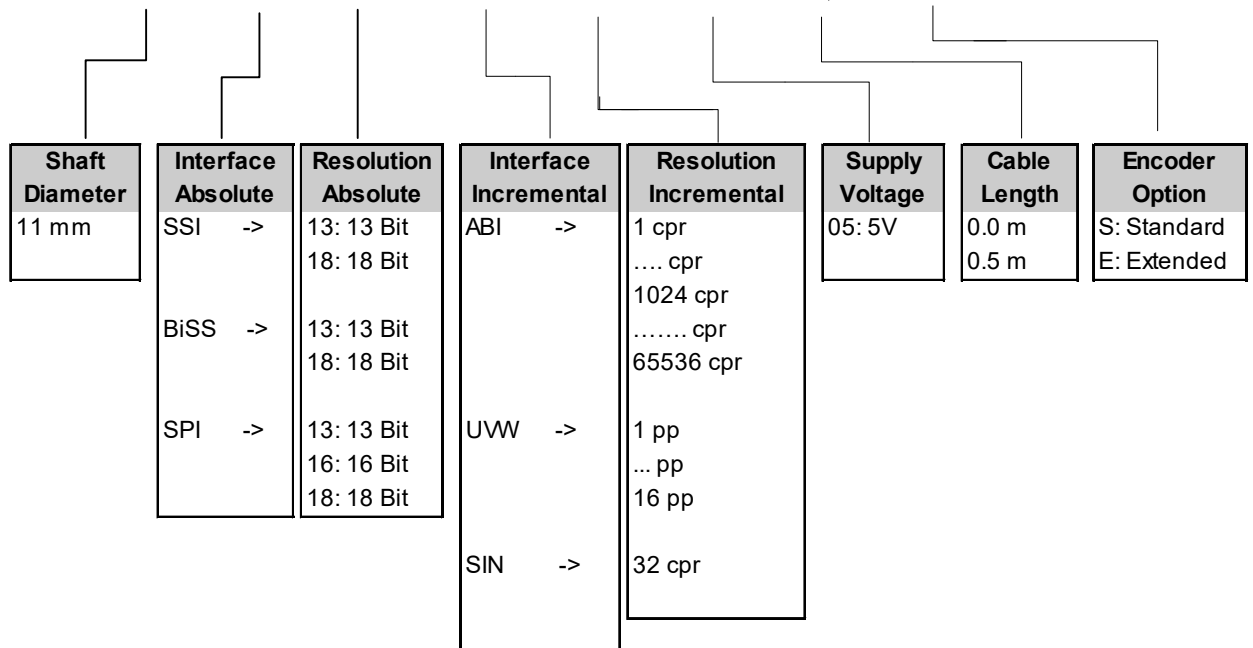

The incremental interface and the absolute interface are chosen freely in combination.

Pin-out description

<i>signal description</i>					<i>connector</i>		<i>cable</i>
SPI	SSI, BiSS	ABI	UVW	Sin/Cos	Supply	Pin No.	color of wire
					GND	12	blue
					UB	11	red
		A+	U+	Sin+		10	green
		A-	U-			9	yellow
		I-	W-	Cos-		8	purple
		I+	W+	Cos+		7	black
		B-	V-			6	white
		B+	V+	Sin- *		5	brown
MISO	Da+					4	pink
MOSI	Cl-					3	pink/grey
NCS	Da-					2	grey
SCLK	Cl+					1	blue/red

* for shielded and twisted-pair cable Sin- is yellow

Available accessories

Art. No.: 103674

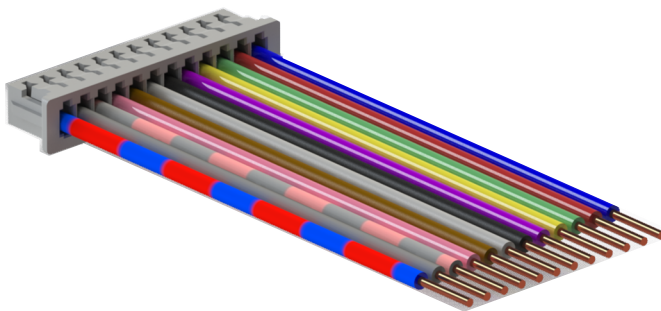

Standard cable length 500 mm
(AWG 28)